

Emmy Noether

Symmetry	Conservation Law
Translation in time	Energy
Translation in space	Momentum
Rotation	Angular momentum
Gauge transformation	Charge



Extremely powerful idea. Most of modern particle physics based upon the aesthetic concepts of symmetries

Emmy Noether

Not going to go into mathematical details of group theory. Perhaps some of you have already taken a group theory course here?



We move instead to discussing angular momentum, which will end up providing rich structure to bound states in particle physics

Reminder from QM that even fundamental point particles (such as electrons, muons and W bosons) can carry intrinsic spin, and that we **cannot** measure all 3 components of \mathbf{L} simultaneously

Angular momentum - a reminder

We cannot measure L_x , L_y and L_z simultaneously, but we can measure L^2 and also L_z (by convention - nothing special about z direction!) simultaneously. They can take only discrete values

$$\mathbf{L}^2 Q = l(l + 1)Q$$

$$l = 0, 1, 2, 3, \dots$$

$$L_z Q = m_l Q$$

$$m_l = -l, -l + 1, -l + 2, \dots, 0, l - 2, l - 1, l$$

$2l + 1$ values for m_L

Reminder: $\hbar = 1$ for us!

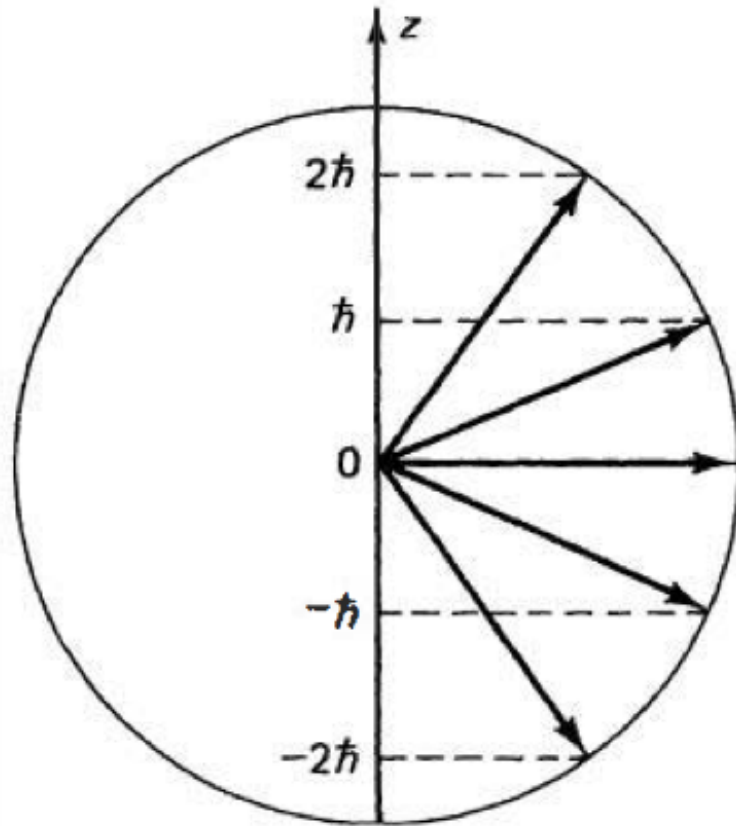

$l=2$, so $|\mathbf{L}|^2 = (2)(2+1)$
 $|\mathbf{L}| = \text{sqrt}(6)$
 L_z can be $-2, -1, 0, 1, 2$

$$S_z Q = m_s Q$$

$$m_s = -s, -s + 1, -s + 2, \dots, 0, s - 2, s - 1, s$$

$$S^2 Q = (\mathbf{S} \cdot \mathbf{S}) Q = s(s + 1) Q$$

$$s = 0, \frac{1}{2}, 1, \frac{3}{2}, 2, \frac{5}{2}, 3, \dots$$

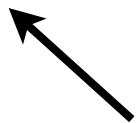

Different than orbital angular momentum (s can take half-integer values)

Other difference between s and l

Particle	Spin
electron, muon, tau, neutrinos	1/2
quarks	1/2
W^\pm , Z, γ , gluon	1
Higgs boson	0
π , K	0
proton, neutron	1/2
J/Ψ , ρ	1
Δ , Ω^-	3/2

s is an intrinsic quantity associated with the particle - we usually call it the **spin**. **Half-integer spin = fermion**, **integer spin = boson**

$|l m_l \rangle$ $|s m_s \rangle$ We use the ket notation to define j and j_z

$$|j_1 m_{j1} \rangle + |j_2 m_{j2} \rangle = |j m_j \rangle$$

What is $|j m_j \rangle$?
How to add two kets? How does angular momentum add?

m_j is the easy one:
 $m_j = m_{j1} + m_{j2}$

$$|j_1 m_{j_1} \rangle + |j_2 m_{j_2} \rangle = |j m_j \rangle$$

m_j is the easy one:

$$m_j = m_{j_1} + m_{j_2}$$

$$j = |j_1 - j_2|, |j_1 - j_2| + 1, |j_1 - j_2| + 2, \\ |j_1 + j_2| - 2, |j_1 + j_2| - 1, |j_1 + j_2|$$

$j_1=5, j_2=2, j$ can be 3,4,5,6 or 7

What are the probabilities for the different values?

Clebsch-Gordan coefficients (we don't derive them here)

From Particle Data Group

36. Clebsch-Gordan coefficients 1

36. CLEBSCH-GORDAN COEFFICIENTS, SPHERICAL HARMONICS,
AND d FUNCTIONSNote: A square-root sign is to be understood over every coefficient, e.g., for $-8/15$ read $-\sqrt{8/15}$.

Notation:

J	J	...
M	M	...
m_1	m_2	
m_1	m_2	Coefficients
\vdots	\vdots	
\vdots	\vdots	

$$1/2 \times 1/2$$

	1		
+1/2	+1/2	1	0
+1/2	-1/2	1/2	1/2
-1/2	+1/2	1/2	-1/2
	-1/2	-1/2	1

$$Y_1^0 = \sqrt{\frac{3}{4\pi}} \cos \theta$$

$$Y_1^1 = -\sqrt{\frac{3}{8\pi}} \sin \theta e^{i\phi}$$

$$Y_2^0 = \sqrt{\frac{5}{4\pi}} \left(\frac{3}{2} \cos^2 \theta - \frac{1}{2} \right)$$

$$Y_2^1 = -\sqrt{\frac{15}{8\pi}} \sin \theta \cos \theta e^{i\phi}$$

$$Y_2^2 = \frac{1}{4} \sqrt{\frac{15}{2\pi}} \sin^2 \theta e^{2i\phi}$$

$$2 \times 1/2$$

	5/2		
+2	+1/2	5/2	3/2
+2	-1/2	1/5	4/5
+1	+1/2	4/5	-1/5
		5/2	3/2
		1/2	1/2

		5/2	3/2
+1	-1/2	2/5	3/5
0	+1/2	3/5	-2/5
		-1/2	-1/2
		0	-1/2
		3/5	2/5
		2/5	-3/5
		-3/2	-3/2

$$3/2 \times 1/2$$

	2		
+3/2	+1/2	2	1
+3/2	-1/2	1/4	3/4
+1/2	+1/2	3/4	-1/4
		2	1
		1/2	1/2
		1/2	-1/2
		-1	-1

$$1 \times 1/2$$

	3/2		
+1	+1/2	3/2	1/2
+1	-1/2	1/3	2/3
0	+1/2	2/3	-1/3
		3/2	1/2
		1/2	-1/2

$$2 \times 1$$

	3		
+2	+1	3	2
+2	0	1/3	2/3
+1	+1	2/3	-1/3
		3	2
		1	1
		1	1

$$3/2 \times 1$$

	5/2		
+3/2	+1	5/2	3/2
+3/2	0	2/5	3/5
+1/2	+1	3/5	-2/5
		5/2	3/2
		1/2	1/2
		1/2	1/2

$$1 \times 1$$

	2		
+1	+1	2	1
+1	0	1/2	1/2
0	+1	1/2	-1/2
		2	1
		1	0
		0	0

		3	2	1
+1	-1	1/5	1/2	3/10
0	0	3/5	0	-2/5
-1	+1	1/5	-1/2	3/10
		3	2	1
		-1	-1	-1

		5/2	3/2	1/2
+1/2	-1	3/10	8/15	1/6
-1/2	0	3/5	-1/15	-1/3
-3/2	+1	1/10	-2/5	1/2
		-1/2	-1/2	-1/2
		5/2	3/2	1/2
		-3/2	-3/2	

		2	1
+1	-1	1/6	1/2
0	0	2/3	0
-1	+1	1/6	-1/2
		2	1
		1	0
		0	0

		3	2
0	-1	2/5	1/2
-1	0	8/15	-1/6
-2	+1	1/15	-1/3
		3	2
		-2	-2

		5/2	3/2
-1/2	-1	3/5	2/5
-3/2	0	2/5	-3/5
		5/2	3/2
		-3/2	-3/2
		1	1

$$Y_\ell^{-m} = (-1)^m Y_\ell^{m*}$$

$$d_{m,0}^\ell = \sqrt{\frac{4\pi}{2\ell+1}} Y_\ell^m e^{-im\phi}$$

$$\begin{aligned} & (j_1 j_2 m_1 m_2 | j_1 j_2 J M) \\ & = (-1)^{J-j_1-j_2} (j_2 j_1 m_2 m_1 | j_2 j_1 J M) \end{aligned}$$

What are the possible values of the spin of a meson if the quark and anti-quark have orbital angular momentum = 0?

Spin=0: pseudoscalar mesons (pion, kaons,
etas)

(Scalar meaning spin 0)

Spin = 1: vector mesons (rhos, K^* , phi,
omega)

(Vector meaning spin 1)

What do we get if we add the angular momenta of 3 quarks, to form a baryon? What can the spin be? Does orbital angular momentum change anything?

Electron in a hydrogen atom is in the $|2 -1\rangle$ state, and spin state $|\frac{1}{2} \frac{1}{2}\rangle$. If we measure J^2 what values might we get, and with what probability? The first part should be easy

For the second part...

From Particle Data Group

36. CLEBSCH-GORDAN COEFFICIENTS, SPHERICAL HARMONICS, AND d FUNCTIONS

Note: A square-root sign is to be understood over every coefficient. e.g., for $-8/15$ read $-\sqrt{8/15}$.

Notation:

J	J	...
M	M	...
m_1	m_2	
m_1	m_2	Coefficients
\vdots	\vdots	
\vdots	\vdots	

$1/2 \times 1/2$

	1		
+1	1	0	
+1/2 + 1/2	1	0	0
+1/2 - 1/2	1/2	1/2	1
-1/2 + 1/2	1/2	-1/2	-1
-1/2 - 1/2			1

$$Y_1^0 = \sqrt{\frac{3}{4\pi}} \cos \theta$$

$$Y_1^1 = -\sqrt{\frac{3}{8\pi}} \sin \theta e^{i\phi}$$

$$Y_2^0 = \sqrt{\frac{5}{4\pi}} \left(\frac{3}{2} \cos^2 \theta - \frac{1}{2} \right)$$

$$Y_2^1 = -\sqrt{\frac{15}{8\pi}} \sin \theta \cos \theta e^{i\phi}$$

$$Y_2^2 = \frac{1}{4} \sqrt{\frac{15}{2\pi}} \sin^2 \theta e^{2i\phi}$$

$2 \times 1/2$

	5/2	5/2	3/2
+5/2	1	+3/2 + 3/2	
+2 + 1/2	1/5	4/5	5/2
+1 + 1/2	4/5	-1/5	+1/2
			3/2

$1 \times 1/2$

	3/2	3/2	1/2
+3/2	1	+1/2 + 1/2	
+1 + 1/2	1/3	2/3	3/2
+1 - 1/2	2/3	-1/3	1/2
0 + 1/2	0 - 1/2	2/3	1/3
	-1 + 1/2	1/3	-2/3
		-1 - 1/2	3/2

$3/2 \times 1/2$

	2	2	1
+2	1	+1	+1
+3/2 + 1/2	1/4	3/4	2
+3/2 - 1/2	3/4	-1/4	1
+1/2 + 1/2	0	0	2
			1

2×1

	3	3	2
+3	1	+2	+2
+2 + 0	1/3	2/3	3
+2 - 0	2/3	-1/3	2
+1 + 1	0	0	3
			2

$3/2 \times 1$

	5/2	5/2	3/2
+5/2	1	+3/2 + 3/2	
+3/2 + 0	2/5	3/5	5/2
+3/2 - 0	3/5	-2/5	3/2
+1/2 + 1	0	0	1/2
			1/2

1×1

	2	2	1
+2	1	+1	+1
+1 + 0	1/2	1/2	2
+1 - 0	1/2	-1/2	1
0 + 1	0	0	2
			1

+1 - 1	1/5	1/2	3/10
0 + 0	3/5	0	-2/5
-1 + 1	1/5	-1/2	3/10
			3
			2
			1

+1/2 - 1	3/10	8/15	1/6
-1/2 + 0	3/5	-1/15	-1/3
-3/2 + 1	1/10	-2/5	1/2
			5/2
			3/2
			1/2

+1 - 1	1/6	1/2	1/3
0 + 0	2/3	0	-1/3
-1 + 1	1/6	-1/2	1/3
			2
			1
			0

0 - 1	2/5	1/2	1/10
-1 + 0	8/15	-1/6	-3/10
-2 + 1	1/15	-1/3	3/5
			3
			2
			-2

-1/2 - 1	3/5	2/5	5/2
-3/2 + 0	2/5	-3/5	-5/2
			5/2
			3/2
			1

$$Y_\ell^{-m} = (-1)^m Y_\ell^m*$$

$$d_{m,0}^\ell = \sqrt{\frac{4\pi}{2\ell+1}} Y_\ell^m e^{-im\phi}$$

$$\begin{aligned} & (j_1 j_2 m_1 m_2 | j_1 j_2 J M) \\ & = (-1)^{J-j_1-j_2} (j_2 j_1 m_2 m_1 | j_2 j_1 J M) \end{aligned}$$

For the second part...

, e.g., for $-8/15$ read $-\sqrt{8/15}$.

Notation:

J	J	...
M	M	...

m_1	m_2	Coefficients
m_1	m_2	
.	.	
.	.	
.	.	

$$2 \times \frac{1}{2} \begin{array}{|c|c|c|c|} \hline & \frac{5}{2} & & \\ \hline +2 & +\frac{5}{2} & & \\ \hline +2 & +\frac{1}{2} & 1 & \\ \hline \end{array} \begin{array}{|c|c|} \hline \frac{5}{2} & \frac{3}{2} \\ \hline +\frac{3}{2} & +\frac{3}{2} \\ \hline \end{array}$$

$$\begin{array}{|c|c|c|c|} \hline +2 & -\frac{1}{2} & \frac{1}{5} & \frac{4}{5} \\ \hline +1 & +\frac{1}{2} & \frac{4}{5} & -\frac{1}{5} \\ \hline \end{array} \begin{array}{|c|c|} \hline \frac{5}{2} & \frac{3}{2} \\ \hline +\frac{1}{2} & +\frac{1}{2} \\ \hline \end{array}$$

$$\left. \begin{array}{l} \frac{1}{2} \\ \cdot \end{array} \right) \begin{array}{|c|c|c|c|} \hline +1 & -\frac{1}{2} & \frac{2}{5} & \frac{3}{5} \\ \hline 0 & +\frac{1}{2} & \frac{3}{5} & -\frac{2}{5} \\ \hline \end{array} \begin{array}{|c|c|} \hline \frac{5}{2} & \frac{3}{2} \\ \hline -\frac{1}{2} & -\frac{1}{2} \\ \hline \end{array}$$

$$9 e^{i\phi} \begin{array}{|c|c|} \hline 0 & -\frac{1}{2} \\ \hline -1 & +\frac{1}{2} \\ \hline \end{array} \begin{array}{|c|c|} \hline \frac{3}{5} & \frac{2}{5} \\ \hline \frac{2}{5} & -\frac{3}{5} \\ \hline \end{array} \begin{array}{|c|c|} \hline \frac{5}{2} & \frac{3}{2} \\ \hline -\frac{3}{2} & -\frac{3}{2} \\ \hline \end{array}$$

$$\frac{3}{2} \times \frac{1}{2} \begin{array}{|c|c|c|c|} \hline & 2 & & \\ \hline +2 & & & \\ \hline +2 & & 2 & 1 \\ \hline \end{array} \begin{array}{|c|c|} \hline -1 & -\frac{1}{2} \\ \hline -2 & +\frac{1}{2} \\ \hline \end{array} \begin{array}{|c|c|} \hline \frac{4}{5} & \frac{1}{5} \\ \hline \frac{1}{5} & -\frac{4}{5} \\ \hline \end{array} \begin{array}{|c|} \hline \frac{5}{2} \\ \hline -\frac{5}{2} \\ \hline \end{array}$$

$$\phi \begin{array}{|c|c|c|c|} \hline +\frac{3}{2} & +\frac{1}{2} & 1 & \\ \hline +1 & & & 1 \\ \hline \end{array} \begin{array}{|c|c|} \hline -2 & -\frac{1}{2} \\ \hline & 1 \\ \hline \end{array}$$

Spin 1/2 objects

All fundamental matter particles (leptons and quarks) carry spin 1/2. So do neutrons and protons (why can't they have spin 1 or 0?)

Spin 1/2 objects can have spin up ($m_s = +1/2$) or spin down ($m_s = -1/2$). Represent them with spinors:

$$|j \ m_j^{up}\rangle = \left| \frac{1}{2} \ \frac{1}{2} \right\rangle = \begin{pmatrix} 1 \\ 0 \end{pmatrix}$$

$$|j \ m_j^{down}\rangle = \left| \frac{1}{2} \ -\frac{1}{2} \right\rangle = \begin{pmatrix} 0 \\ 1 \end{pmatrix}$$

$$\begin{pmatrix} \alpha \\ \beta \end{pmatrix} = \alpha \begin{pmatrix} 1 \\ 0 \end{pmatrix} + \beta \begin{pmatrix} 0 \\ 1 \end{pmatrix}$$

$$\hat{S}_x = \frac{1}{2} \begin{pmatrix} 0 & 1 \\ 1 & 0 \end{pmatrix}$$

$$\hat{S}_y = \frac{1}{2} \begin{pmatrix} 0 & -i \\ i & 0 \end{pmatrix}$$

$$\hat{S}_z = \frac{1}{2} \begin{pmatrix} 1 & 0 \\ 0 & -1 \end{pmatrix}$$

$$\sigma_x = \begin{pmatrix} 0 & 1 \\ 1 & 0 \end{pmatrix}$$

$$\sigma_y = \begin{pmatrix} 0 & -i \\ i & 0 \end{pmatrix}$$

$$\sigma_z = \begin{pmatrix} 1 & 0 \\ 0 & -1 \end{pmatrix}$$

Spin
operators

Pauli spin
matrices

$$|\alpha|^2 + |\beta|^2 = ?$$

Flavor symmetries

$$\begin{aligned}
 M(\text{proton}) &= 938.272046 \text{ MeV} && \text{Same mass to} \\
 M(\text{neutron}) &= 939.565379 \text{ MeV} && \text{0.1%!}
 \end{aligned}$$

So perhaps they are different types of the “same” object (call it a **nucleon**)

$$\text{Nucleon} = \begin{pmatrix} \alpha \\ \beta \end{pmatrix}$$

Proton is “up” by convention

$$\text{Proton} = \begin{pmatrix} 1 \\ 0 \end{pmatrix}$$

$$\text{Neutron} = \begin{pmatrix} 0 \\ 1 \end{pmatrix}$$

Instead of spin we call this **isospin** (lousy name!)

Isospin

Instead of spin we call
this **isospin**

By analogy with regular spin,
both p and n have isospin = 1/2

$$\text{Proton} = \begin{pmatrix} 1 \\ 0 \end{pmatrix}$$
$$\text{Neutron} = \begin{pmatrix} 0 \\ 1 \end{pmatrix}$$

By analogy proton has $I_3 = +1/2$

By analogy neutron has $I_3 = -1/2$

(Could call it I_z but we are not dealing with real,
ordinary physical space)

Isospin

$$p = \left| \begin{array}{c} 1 \\ \frac{1}{2} \end{array} \right\rangle$$

$$n = \left| \begin{array}{c} 1 \\ \frac{1}{2} \end{array} \right\rangle$$

Idea: QCD interactions are invariant under rotations in isospin space

Emmy Noether:
This means that
isospin is
conserved in
strong
interactions

Symmetry	Conservation Law
Translation in time	Energy
Translation in space	Momentum
Rotation	Angular momentum
Gauge transformation	Charge



Isospin

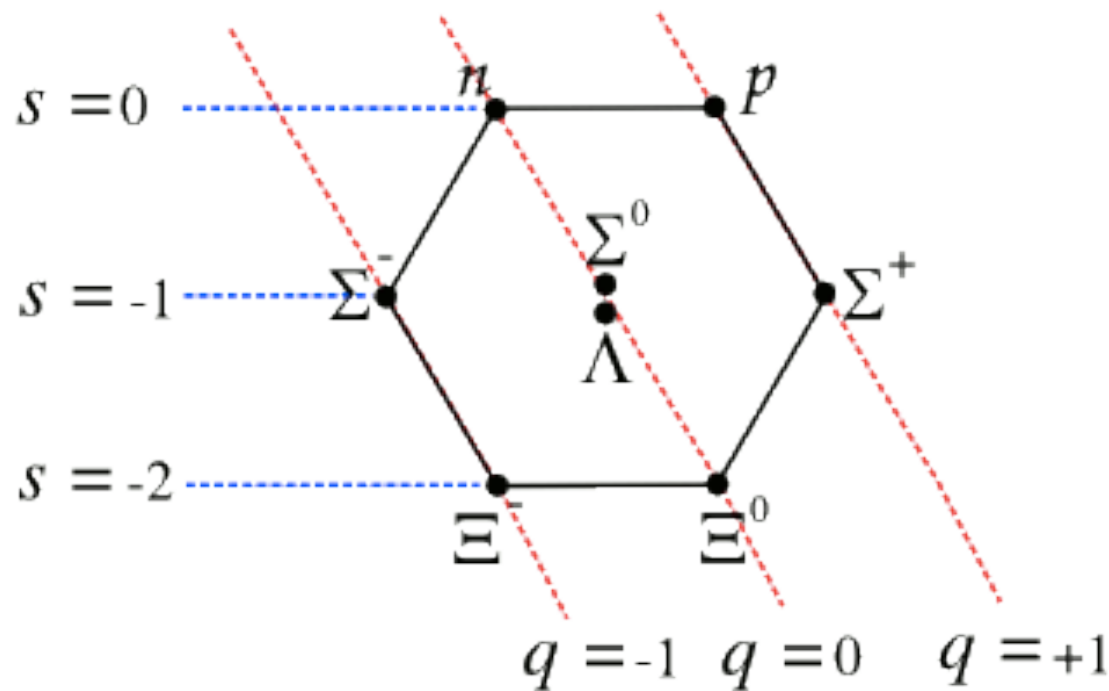

PDG:

Σ^+ : 1189 MeV

Σ^0 : 1193 MeV

Σ^- : 1197 MeV

Λ : 1116 MeV

Ξ^0 : 1315 MeV

Ξ^- : 1322 MeV

$$p = \left| \begin{array}{cc} 1 & 1 \\ \frac{1}{2} & \frac{1}{2} \end{array} \right\rangle$$

$$n = \left| \begin{array}{cc} 1 & -1 \\ \frac{1}{2} & \frac{1}{2} \end{array} \right\rangle$$

$$\Sigma^+ = |1\ 1\rangle$$

$$\Sigma^0 = |1\ 0\rangle$$

$$\Sigma^- = |1\ -1\rangle$$

$$\Lambda = |0\ 0\rangle$$

$$\Xi^0 = \left| \frac{1}{2} + \frac{1}{2} \right\rangle$$

$$\Xi^- = \left| \frac{1}{2} - \frac{1}{2} \right\rangle$$

Isospin counting

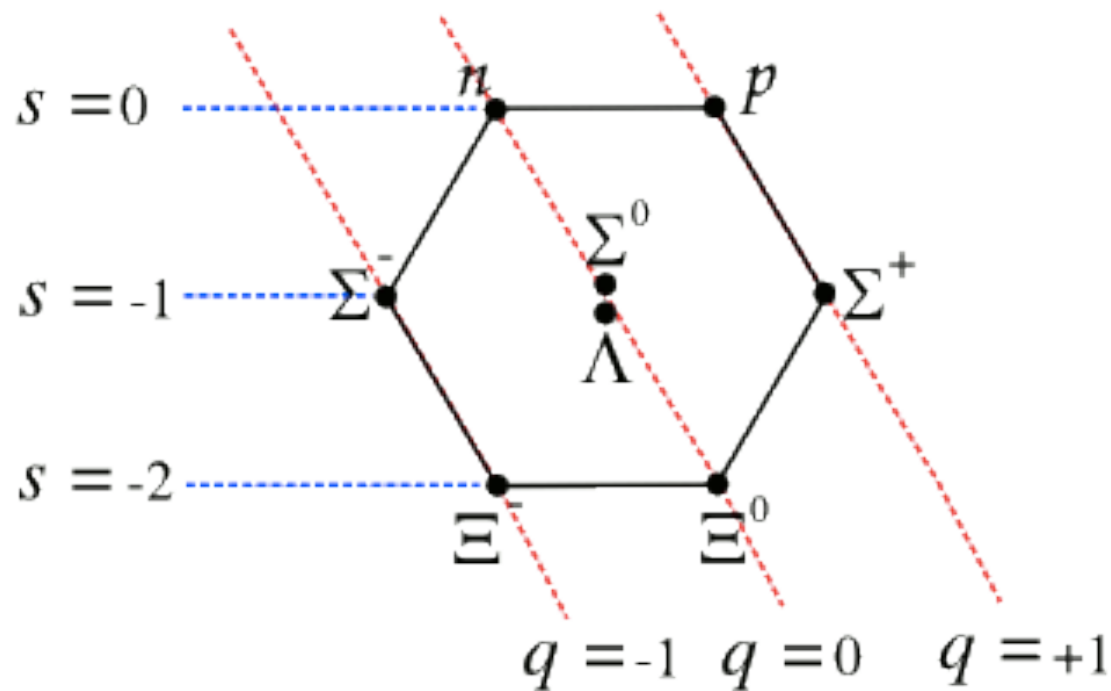

I_3 goes from -1 to 1 so multiplicity is $2I+1$. By convention, highest charge gets highest I_3

$$p = \left| \begin{array}{cc} 1 & 1 \\ \frac{1}{2} & \frac{1}{2} \end{array} \right\rangle$$

$$n = \left| \begin{array}{cc} 1 & -1 \\ \frac{1}{2} & \frac{1}{2} \end{array} \right\rangle$$

$$\Sigma^+ = |1 \ 1\rangle$$

$$\Sigma^0 = |1 \ 0\rangle$$

$$\Sigma^- = |1 \ -1\rangle$$

$$\Lambda = |0 \ 0\rangle$$

$$\Xi^0 = \left| \frac{1}{2} \ + \ \frac{1}{2} \right\rangle$$

$$\Xi^- = \left| \frac{1}{2} \ - \ \frac{1}{2} \right\rangle$$

Isospin for mesons

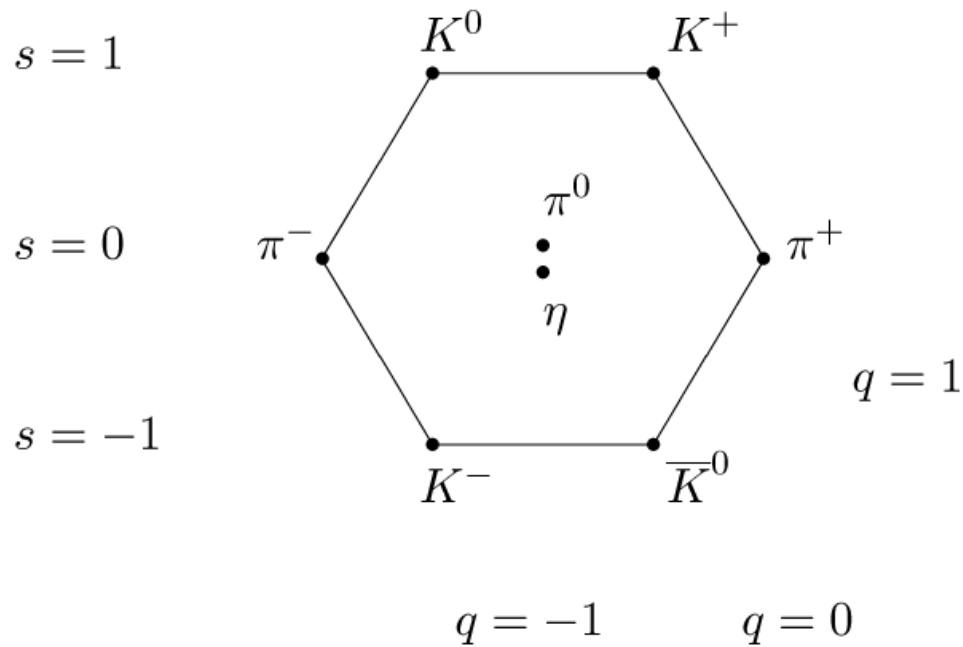

PDG:

K^0 : 498 MeV

K^\pm : 494 MeV

π^0 : 135 MeV

π^\pm : 140 MeV

η : 548 MeV

$$\pi^+ = |1\ 1\rangle$$

$$\pi^0 = |1\ 0\rangle$$

$$\pi^- = |1\ -1\rangle$$

I_3 is conserved by electromagnetic forces, but I is not.

Weak interactions don't conserve isospin at all.

And of course, strong forces conserve it as we have discussed

Combining isospin

Combining two $1/2 \times 1/2$ particles

A pair of nucleons can have total isospin $+1$ or 0 . What are the combinations of n and p ?

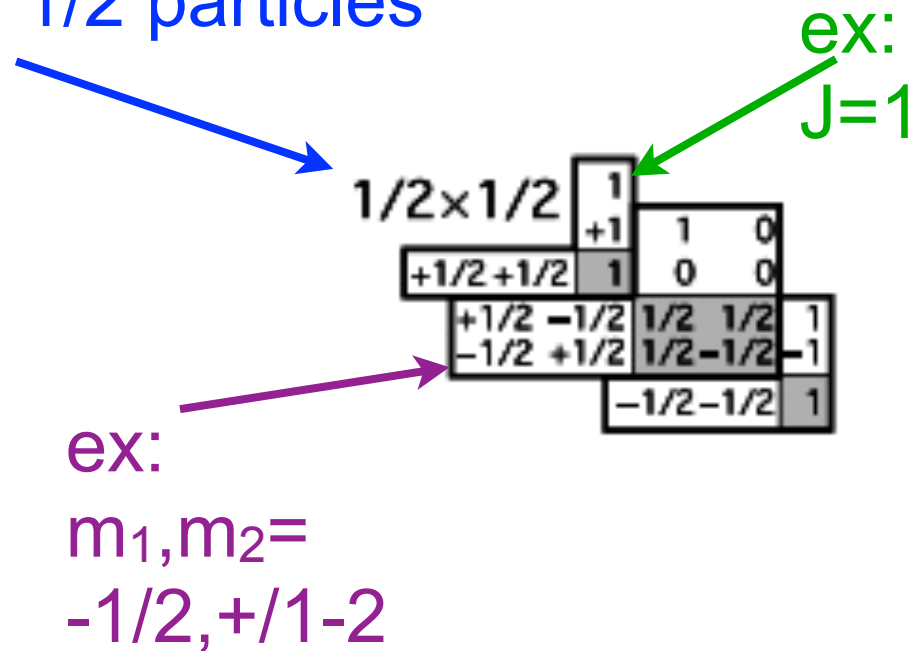

$$p = \left| \begin{array}{cc} 1 & 1 \\ \frac{1}{2} & \frac{1}{2} \end{array} \right\rangle$$

$$n = \left| \begin{array}{cc} 1 & -1 \\ \frac{1}{2} & \frac{1}{2} \end{array} \right\rangle$$

Combining isospin

Combining two $1/2 \times 1/2$ particles

$$\left| \frac{1}{2} \frac{1}{2} \right\rangle + \left| \frac{1}{2} \frac{1}{2} \right\rangle = \left| 1 \ 1 \right\rangle$$

$$\left| \frac{1}{2} \frac{1}{2} \right\rangle + \left| \frac{1}{2} \frac{-1}{2} \right\rangle = \sqrt{\frac{1}{2}} \left| 1 \ 0 \right\rangle + \sqrt{\frac{1}{2}} \left| 0 \ 0 \right\rangle$$

$$\left| \frac{1}{2} \frac{-1}{2} \right\rangle + \left| \frac{1}{2} \frac{1}{2} \right\rangle = \sqrt{\frac{1}{2}} \left| 1 \ 0 \right\rangle - \sqrt{\frac{1}{2}} \left| 0 \ 0 \right\rangle$$

$$\left| \frac{-1}{2} \frac{1}{2} \right\rangle + \left| \frac{-1}{2} \frac{1}{2} \right\rangle = \left| 1 \ -1 \right\rangle$$

1/2 x 1/2

	1		
	+1	1	0
+1/2 +1/2	1	0	0
+1/2 -1/2	1/2	1/2	1
-1/2 +1/2	1/2	-1/2	-1
	-1/2 -1/2		1

ex:
J=1
m=1

ex:
m₁, m₂=
-1/2, +1-2

Putting it together

$$\left| \frac{1}{2} \frac{1}{2} \right\rangle + \left| \frac{1}{2} \frac{1}{2} \right\rangle = |1 \ 1 \rangle$$

$$pp = |1 \ 1 \rangle$$

$$\left| \frac{1}{2} \frac{1}{2} \right\rangle + \left| \frac{1}{2} \frac{-1}{2} \right\rangle = \sqrt{\frac{1}{2}} |1 \ 0 \rangle + \sqrt{\frac{1}{2}} |0 \ 0 \rangle$$

$$pn = \sqrt{\frac{1}{2}} (|1 \ 0 \rangle + |0 \ 0 \rangle)$$

$$\left| \frac{1}{2} \frac{-1}{2} \right\rangle + \left| \frac{1}{2} \frac{1}{2} \right\rangle = \sqrt{\frac{1}{2}} |1 \ 0 \rangle - \sqrt{\frac{1}{2}} |0 \ 0 \rangle$$

$$np = \sqrt{\frac{1}{2}} (|1 \ 0 \rangle - |0 \ 0 \rangle)$$

$$\left| \frac{-1}{2} \frac{1}{2} \right\rangle + \left| \frac{-1}{2} \frac{1}{2} \right\rangle = |1 \ -1 \rangle$$

$$nn = |1 \ -1 \rangle$$

$$pp = |1\ 1\rangle$$

$$pn = \sqrt{\frac{1}{2}} (|1\ 0\rangle + |0\ 0\rangle)$$

$$np = \sqrt{\frac{1}{2}} (|1\ 0\rangle - |0\ 0\rangle)$$

$$nn = |1\ -1\rangle$$



$$pp = |1\ 1\rangle$$

$$\frac{1}{\sqrt{2}} (pn + np) = |1\ 0\rangle$$

$$\frac{1}{\sqrt{2}} (pn - np) = |0\ 0\rangle$$

$$nn = |1\ -1\rangle$$

What is a deuteron

$$pp = |1 \ 1 \rangle$$

$$\frac{1}{\sqrt{2}} (pn + np) = |1 \ 0 \rangle$$

$$\frac{1}{\sqrt{2}} (pn - np) = |0 \ 0 \rangle$$

$$nn = |1 \ -1 \rangle$$

The deuteron is an 'np' bound state. There are no nn and no pp bound states. Since isospin is conserved by strong interactions, if the $|1 \ 0\rangle$ state is a bound state, then so must be the $|1 \ -1\rangle$ and $|1 \ 1\rangle$ states, which is not the case. So deuteron must be isosinglet $|0 \ 0\rangle$

Nucleon scattering

$$p + p \rightarrow d + \pi^+ \quad |1 \ 1\rangle$$

$$p + n \rightarrow d + \pi^0 \quad |1 \ 0\rangle$$

$$n + n \rightarrow d + \pi^- \quad |1 \ -1\rangle$$

d is isosinglet ($I=0$) so
it adds no isospin to
objects on right

$$pp = |1 \ 1\rangle$$

$$pn = \sqrt{\frac{1}{2}} (|1 \ 0\rangle + |0 \ 0\rangle)$$

$$np = \sqrt{\frac{1}{2}} (|1 \ 0\rangle - |0 \ 0\rangle)$$

$$nn = |1 \ -1\rangle$$

$$\pi^+ = |1 \ 1\rangle$$

$$\pi^0 = |1 \ 0\rangle$$

$$\pi^- = |1 \ -1\rangle$$

Nucleon scattering

$$p + p \rightarrow d + \pi^+ \quad |1 \ 1\rangle \rightarrow |1 \ 1\rangle$$

$$p + n \rightarrow d + \pi^0 \quad 1/\sqrt{2}[|1 \ 0\rangle + |0 \ 0\rangle] \rightarrow |1 \ 0\rangle$$

$$n + n \rightarrow d + \pi^- \quad |1 \ -1\rangle \rightarrow |1 \ -1\rangle$$

$$pp = |1 \ 1\rangle$$

$$pn = \sqrt{\frac{1}{2}} (|1 \ 0\rangle + |0 \ 0\rangle)$$

$$np = \sqrt{\frac{1}{2}} (|1 \ 0\rangle - |0 \ 0\rangle)$$

$$nn = |1 \ -1\rangle$$

$$\pi^+ = |1 \ 1\rangle$$

$$\pi^0 = |1 \ 0\rangle$$

$$\pi^- = |1 \ -1\rangle$$

$$p + p \rightarrow d + \pi^+ \quad |1 \ 1\rangle \rightarrow |1 \ 1\rangle$$

$$p + n \rightarrow d + \pi^0 \quad 1/\sqrt{2}(|1 \ 0\rangle + |0 \ 0\rangle) \rightarrow |1 \ 0\rangle$$

$$n + n \rightarrow d + \pi^- \quad |1 \ -1\rangle \rightarrow |1 \ -1\rangle$$

Assuming that these are purely QCD scattering, then middle reaction must have matrix element for this process $1/\sqrt{2}$ of the others (since isospin is conserved), so will proceed at half the rate

Another example

$$\pi^+p \rightarrow \pi^+p$$

$$\pi^-p \rightarrow \pi^-p$$

$$\pi^0p \rightarrow \pi^0p$$

$$\pi^+n \rightarrow \pi^+n$$

$$\pi^-n \rightarrow \pi^-n$$

$$\pi^0n \rightarrow \pi^0n$$

$$\pi^+n \rightarrow \pi^0p$$

$$\pi^0n \rightarrow \pi^-p$$

$$\pi^0p \rightarrow \pi^+n$$

$$\pi^-p \rightarrow \pi^0n$$

Pion has $I=1$ and n/p have $I=1/2$ so total isospin can be $1/2$ or $3/2$

Let's do this together

From Particle Data Group

$1 \times 1/2$	$3/2$		
	$+3/2$	$3/2$	$1/2$
$+1$	$+1/2$	1	$+1/2$
	$+1/2$	$+1/2$	$+1/2$
	$+1$	$-1/2$	$1/3$
	0	$+1/2$	$2/3$
		$2/3$	$-1/3$
		$3/2$	$1/2$
		$-1/2$	$-1/2$
		0	$-1/2$
		-1	$+1/2$
		$2/3$	$1/3$
		$1/3$	$-2/3$
		$3/2$	$3/2$
		$-3/2$	$-3/2$
		-1	$-1/2$
		1	

Pion + nucleon isospin

$$\pi^+ + p : |1 \ 1 \rangle = \left| \frac{1}{2} \ \frac{1}{2} \right\rangle = \left| \frac{3}{2} \ \frac{3}{2} \right\rangle$$

$$\pi^0 + p : |1 \ 0 \rangle = \left| \frac{1}{2} \ \frac{1}{2} \right\rangle = \sqrt{\frac{2}{3}} \left| \frac{3}{2} \ \frac{1}{2} \right\rangle - \frac{1}{\sqrt{3}} \left| \frac{1}{2} \ \frac{1}{2} \right\rangle$$

$$\pi^- + p : |1 \ -1 \rangle = \left| \frac{1}{2} \ \frac{1}{2} \right\rangle = \sqrt{\frac{1}{3}} \left| \frac{3}{2} \ \frac{-1}{2} \right\rangle - \sqrt{\frac{2}{3}} \left| \frac{1}{2} \ \frac{-1}{2} \right\rangle$$

$$\pi^+ + n : |1 \ 1 \rangle = \left| \frac{1}{2} \ \frac{-1}{2} \right\rangle = \sqrt{\frac{1}{3}} \left| \frac{3}{2} \ \frac{1}{2} \right\rangle + \sqrt{\frac{2}{3}} \left| \frac{1}{2} \ \frac{1}{2} \right\rangle$$

$$\pi^0 + n : |1 \ 0 \rangle = \left| \frac{1}{2} \ \frac{-1}{2} \right\rangle = \sqrt{\frac{2}{3}} \left| \frac{3}{2} \ \frac{-1}{2} \right\rangle + \frac{1}{\sqrt{3}} \left| \frac{1}{2} \ \frac{-1}{2} \right\rangle$$

$$\pi^- + n : |1 \ -1 \rangle = \left| \frac{1}{2} \ \frac{-1}{2} \right\rangle = \left| \frac{3}{2} \ \frac{-3}{2} \right\rangle$$

Pion + nucleon scattering

$$\pi^+ p \rightarrow \pi^+ p : \left| \frac{3}{2} \frac{3}{2} \right\rangle \rightarrow \left| \frac{3}{2} \frac{3}{2} \right\rangle$$

$$\pi^- p \rightarrow \pi^- p : \sqrt{\frac{1}{3}} \left| \frac{3}{2} \frac{-1}{2} \right\rangle - \sqrt{\frac{2}{3}} \left| \frac{1}{2} \frac{-1}{2} \right\rangle \rightarrow \sqrt{\frac{1}{3}} \left| \frac{3}{2} \frac{-1}{2} \right\rangle - \sqrt{\frac{2}{3}} \left| \frac{1}{2} \frac{-1}{2} \right\rangle$$

$$\pi^0 p \rightarrow \pi^0 p : \sqrt{\frac{2}{3}} \left| \frac{3}{2} \frac{1}{2} \right\rangle - \frac{1}{\sqrt{3}} \left| \frac{1}{2} \frac{1}{2} \right\rangle \rightarrow \sqrt{\frac{2}{3}} \left| \frac{3}{2} \frac{1}{2} \right\rangle - \frac{1}{\sqrt{3}} \left| \frac{1}{2} \frac{1}{2} \right\rangle$$

$$\pi^+ n \rightarrow \pi^+ n : \sqrt{\frac{1}{3}} \left| \frac{3}{2} \frac{1}{2} \right\rangle + \sqrt{\frac{2}{3}} \left| \frac{1}{2} \frac{1}{2} \right\rangle \rightarrow \sqrt{\frac{1}{3}} \left| \frac{3}{2} \frac{1}{2} \right\rangle + \sqrt{\frac{2}{3}} \left| \frac{1}{2} \frac{1}{2} \right\rangle$$

$$\pi^- n \rightarrow \pi^- n : \left| \frac{3}{2} \frac{-3}{2} \right\rangle \rightarrow \left| \frac{3}{2} \frac{-3}{2} \right\rangle$$

$$\pi^0 n \rightarrow \pi^0 n : \sqrt{\frac{2}{3}} \left| \frac{3}{2} \frac{-1}{2} \right\rangle + \frac{1}{\sqrt{3}} \left| \frac{1}{2} \frac{-1}{2} \right\rangle \rightarrow \sqrt{\frac{2}{3}} \left| \frac{3}{2} \frac{-1}{2} \right\rangle + \frac{1}{\sqrt{3}} \left| \frac{1}{2} \frac{-1}{2} \right\rangle$$

$$\pi^+ n \rightarrow \pi^0 p : \sqrt{\frac{1}{3}} \left| \frac{3}{2} \frac{1}{2} \right\rangle + \sqrt{\frac{2}{3}} \left| \frac{1}{2} \frac{1}{2} \right\rangle \rightarrow \sqrt{\frac{2}{3}} \left| \frac{3}{2} \frac{1}{2} \right\rangle - \frac{1}{\sqrt{3}} \left| \frac{1}{2} \frac{1}{2} \right\rangle$$

$$\pi^0 n \rightarrow \pi^- p : \sqrt{\frac{2}{3}} \left| \frac{3}{2} \frac{-1}{2} \right\rangle + \frac{1}{\sqrt{3}} \left| \frac{1}{2} \frac{-1}{2} \right\rangle \rightarrow \sqrt{\frac{1}{3}} \left| \frac{3}{2} \frac{-1}{2} \right\rangle - \sqrt{\frac{2}{3}} \left| \frac{1}{2} \frac{-1}{2} \right\rangle$$

$$\pi^0 p \rightarrow \pi^+ n : \sqrt{\frac{2}{3}} \left| \frac{3}{2} \frac{1}{2} \right\rangle - \frac{1}{\sqrt{3}} \left| \frac{1}{2} \frac{1}{2} \right\rangle \rightarrow \sqrt{\frac{1}{3}} \left| \frac{3}{2} \frac{1}{2} \right\rangle + \sqrt{\frac{2}{3}} \left| \frac{1}{2} \frac{1}{2} \right\rangle$$

$$\pi^- p \rightarrow \pi^0 n : \sqrt{\frac{1}{3}} \left| \frac{3}{2} \frac{-1}{2} \right\rangle - \sqrt{\frac{2}{3}} \left| \frac{1}{2} \frac{-1}{2} \right\rangle \rightarrow \sqrt{\frac{2}{3}} \left| \frac{3}{2} \frac{-1}{2} \right\rangle + \frac{1}{\sqrt{3}} \left| \frac{1}{2} \frac{-1}{2} \right\rangle$$

Phew

Pion + nucleon scattering

$$\pi^+ p \rightarrow \pi^+ p : \left| \frac{3}{2} \frac{3}{2} \right\rangle \rightarrow \left| \frac{3}{2} \frac{3}{2} \right\rangle \mathcal{M}_{3/2}$$

$$\pi^- p \rightarrow \pi^- p : \sqrt{\frac{1}{3}} \left| \frac{3}{2} \frac{-1}{2} \right\rangle - \sqrt{\frac{2}{3}} \left| \frac{1}{2} \frac{-1}{2} \right\rangle \rightarrow \sqrt{\frac{1}{3}} \left| \frac{3}{2} \frac{-1}{2} \right\rangle - \sqrt{\frac{2}{3}} \left| \frac{1}{2} \frac{-1}{2} \right\rangle$$

$$\pi^0 p \rightarrow \pi^0 p : \sqrt{\frac{2}{3}} \left| \frac{3}{2} \frac{1}{2} \right\rangle - \frac{1}{\sqrt{3}} \left| \frac{1}{2} \frac{1}{2} \right\rangle \rightarrow \sqrt{\frac{2}{3}} \left| \frac{3}{2} \frac{1}{2} \right\rangle - \frac{1}{\sqrt{3}} \left| \frac{1}{2} \frac{1}{2} \right\rangle$$

$$\pi^+ n \rightarrow \pi^+ n : \sqrt{\frac{1}{3}} \left| \frac{3}{2} \frac{1}{2} \right\rangle + \sqrt{\frac{2}{3}} \left| \frac{1}{2} \frac{1}{2} \right\rangle \rightarrow \sqrt{\frac{1}{3}} \left| \frac{3}{2} \frac{1}{2} \right\rangle + \sqrt{\frac{2}{3}} \left| \frac{1}{2} \frac{1}{2} \right\rangle = \sqrt{\frac{1}{3}} \sqrt{\frac{1}{3}} \mathcal{M}_{3/2} + (-\sqrt{\frac{2}{3}})(-\sqrt{\frac{2}{3}}) \mathcal{M}_{1/2} =$$

$$\pi^- n \rightarrow \pi^- n : \left| \frac{3}{2} \frac{-3}{2} \right\rangle \rightarrow \left| \frac{3}{2} \frac{-3}{2} \right\rangle \mathcal{M}_{3/2}$$

$$\frac{1}{3} \mathcal{M}_{3/2} + \frac{2}{3} \mathcal{M}_{1/2}$$

$$\pi^0 n \rightarrow \pi^0 n : \sqrt{\frac{2}{3}} \left| \frac{3}{2} \frac{-1}{2} \right\rangle + \frac{1}{\sqrt{3}} \left| \frac{1}{2} \frac{-1}{2} \right\rangle \rightarrow \sqrt{\frac{2}{3}} \left| \frac{3}{2} \frac{-1}{2} \right\rangle + \frac{1}{\sqrt{3}} \left| \frac{1}{2} \frac{-1}{2} \right\rangle$$

$$\pi^+ n \rightarrow \pi^0 p : \sqrt{\frac{1}{3}} \left| \frac{3}{2} \frac{1}{2} \right\rangle + \sqrt{\frac{2}{3}} \left| \frac{1}{2} \frac{1}{2} \right\rangle \rightarrow \sqrt{\frac{2}{3}} \left| \frac{3}{2} \frac{1}{2} \right\rangle - \frac{1}{\sqrt{3}} \left| \frac{1}{2} \frac{1}{2} \right\rangle$$

$$\pi^0 n \rightarrow \pi^- p : \sqrt{\frac{2}{3}} \left| \frac{3}{2} \frac{-1}{2} \right\rangle + \frac{1}{\sqrt{3}} \left| \frac{1}{2} \frac{-1}{2} \right\rangle \rightarrow \sqrt{\frac{1}{3}} \left| \frac{3}{2} \frac{-1}{2} \right\rangle - \sqrt{\frac{2}{3}} \left| \frac{1}{2} \frac{-1}{2} \right\rangle$$

$$\pi^0 p \rightarrow \pi^+ n : \sqrt{\frac{2}{3}} \left| \frac{3}{2} \frac{1}{2} \right\rangle - \frac{1}{\sqrt{3}} \left| \frac{1}{2} \frac{1}{2} \right\rangle \rightarrow \sqrt{\frac{1}{3}} \left| \frac{3}{2} \frac{1}{2} \right\rangle + \sqrt{\frac{2}{3}} \left| \frac{1}{2} \frac{1}{2} \right\rangle$$

$$\pi^- p \rightarrow \pi^0 n : \sqrt{\frac{1}{3}} \left| \frac{3}{2} \frac{-1}{2} \right\rangle - \sqrt{\frac{2}{3}} \left| \frac{1}{2} \frac{-1}{2} \right\rangle \rightarrow \sqrt{\frac{2}{3}} \left| \frac{3}{2} \frac{-1}{2} \right\rangle + \frac{1}{\sqrt{3}} \left| \frac{1}{2} \frac{-1}{2} \right\rangle$$

Let's work out the rest together

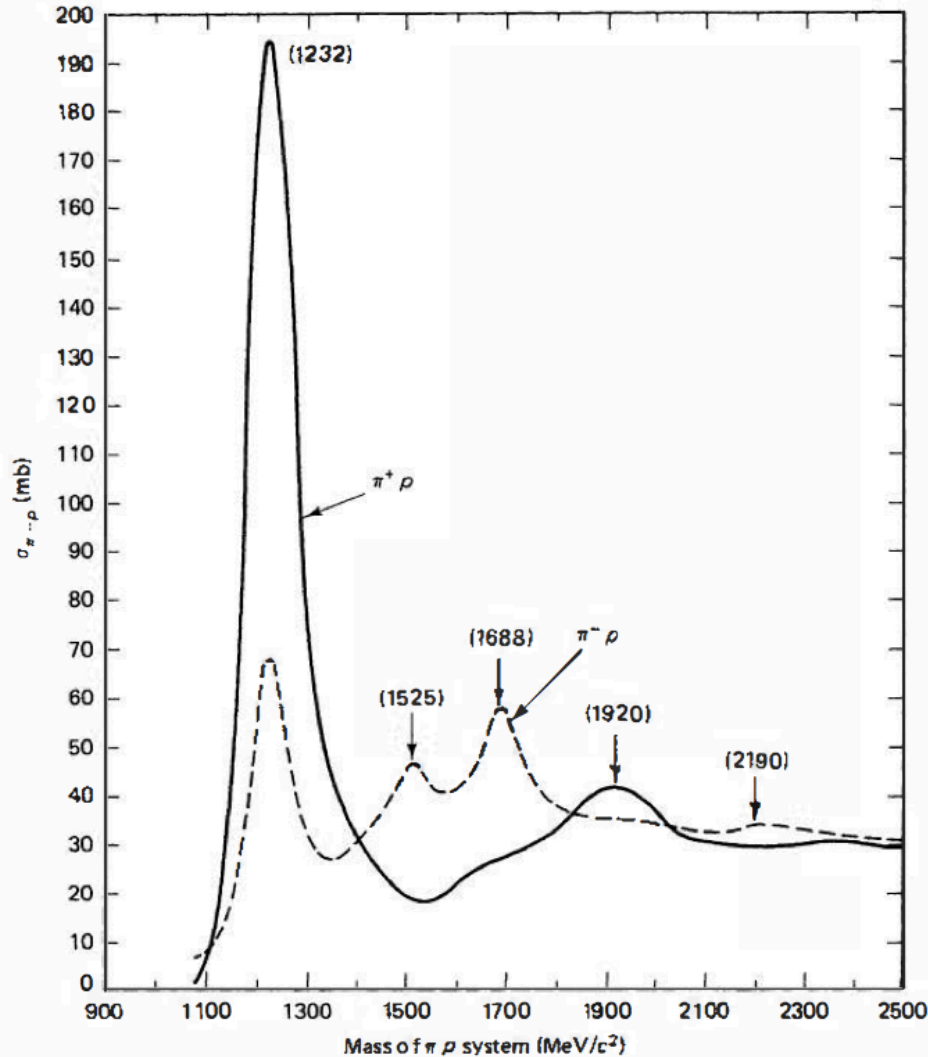

Fig. 4.6 Total cross sections for $\pi^+ p$ (solid line) and $\pi^- p$ (dashed line) scattering. (Source: Gasiorowicz, S. (1966) *Elementary Particle Physics*, John Wiley & Sons, New York, p. 294. Reprinted by permission of John Wiley and Sons, Inc.)

Nice bump at 1232 MeV! This is the Δ^{++} resonance. But it has $I=3/2$, so at this around this mass we know something about the relative nature of matrix elements

If isospin is conserved, why don't neutron and proton have identical mass? Maybe it's electric charge? Well, why do Σ^+ and Σ^- have different masses? Isospin is a very good symmetry because the quarks have a very small mass. But the mass $\neq 0$. Strange quark mass is similar to u and d masses, but not quite as small. And charm quark is significantly more massive.

Σ_c^{++} (uuc): 2454 MeV

Σ_c^+ (udc): 2453 MeV

Σ_c^0 (ddc): 2454 MeV

Σ^+ : 1189 MeV

Σ^0 : 1193 MeV

Σ^- : 1197 MeV

Table 4.4 Quark masses (MeV/c^2)

Quark flavor	Bare mass	Effective mass
<i>u</i>	2	336
<i>d</i>	5	340
<i>s</i>	95	486
<i>c</i>	1300	1550
<i>b</i>	4200	4730
<i>t</i>	174000	177000

Note: These numbers may be a bit old but are not far from the modern values

On to parity



Lee and Yang (1956): Parity conserved in strong and EM processes, but no tests yet for weak interactions

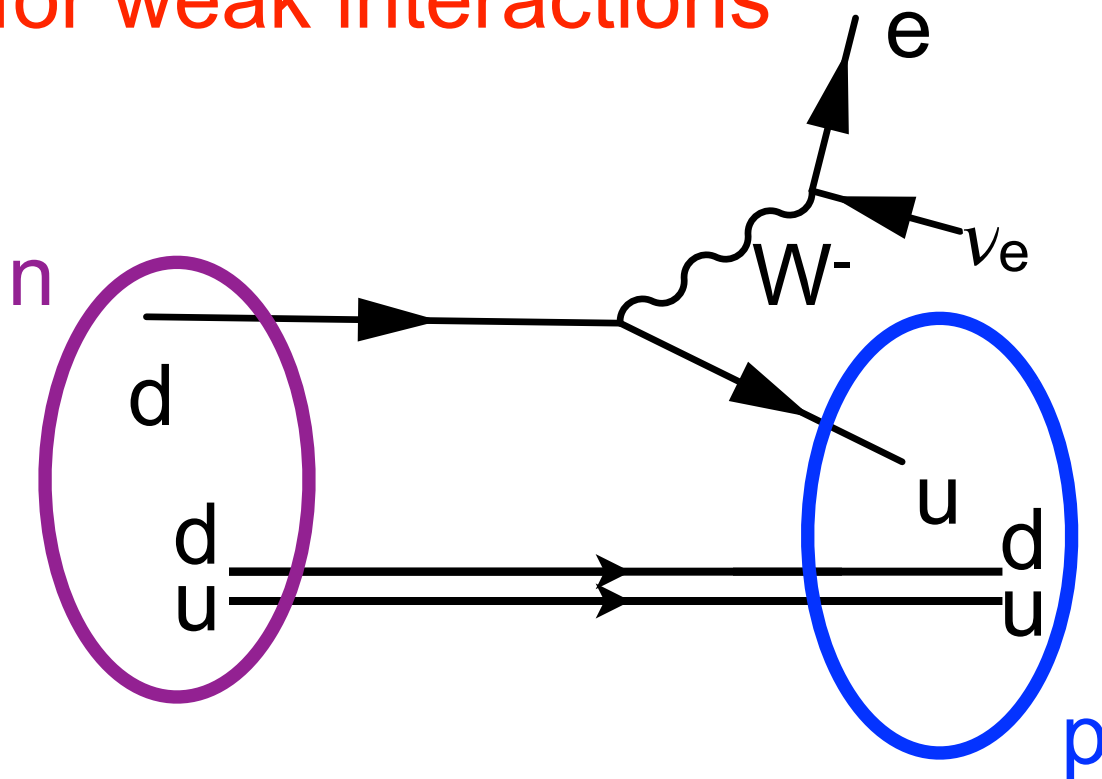

Wu experiment at NIST to test for parity violation in Cobalt-60 radioactive decays

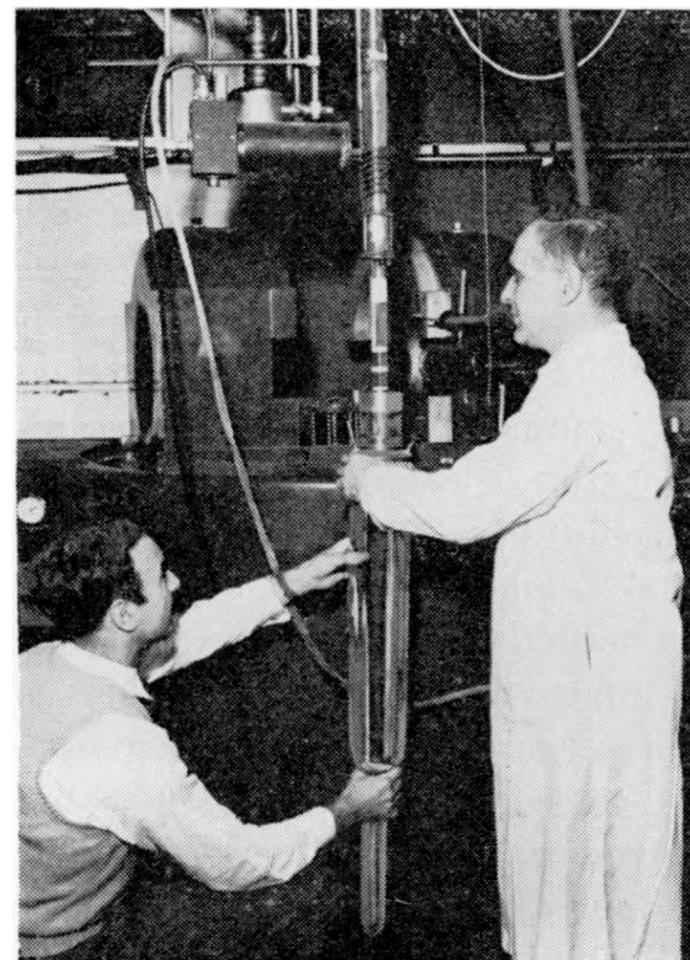

Maximal parity violation

Image from Griffiths

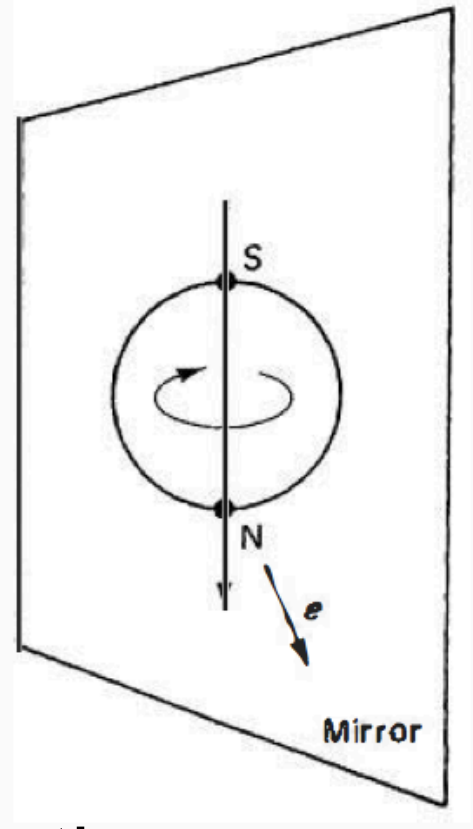
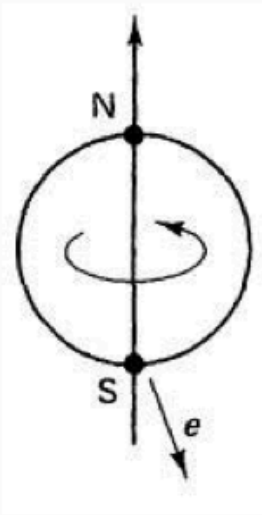

Things look different in a hypothetical mirror!

Spins aligned (via B field) to point in z direction.

Find that electrons overwhelmingly prefer to come out towards south pole!

Image from Griffiths

Helicity = +1

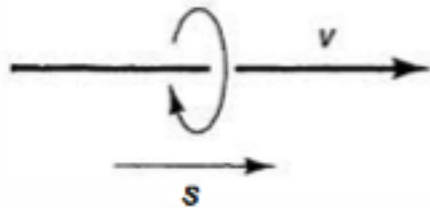

(a) Right-handed

Helicity = -1

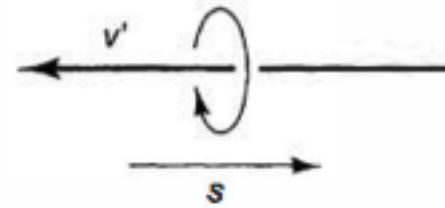

(b) Left-handed

Choose z axis as axis of motion of an object.
Helicity = m_s/s . For spin-1/2 particles, $m_s = \pm 1/2$
so helicity = ± 1 . Only makes sense if another
reference frame cannot overtake the particle
and change the z axis direction! Neutrinos are
 \sim massless so this is OK. What is found?

Image from Griffiths

Helicity = +1

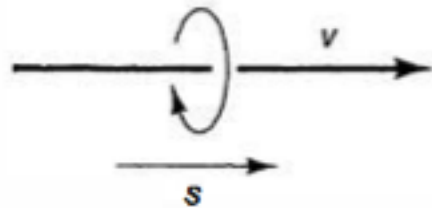

(a) Right-handed

Helicity = -1

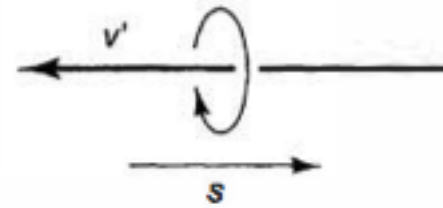

(b) Left-handed

Helicity (neutrino) = -1 (left-handed)

Helicity (anti-neutrino) = +1 (right-handed)

All neutrinos are left-handed**All anti-neutrinos are right-handed**

Image from Griffiths

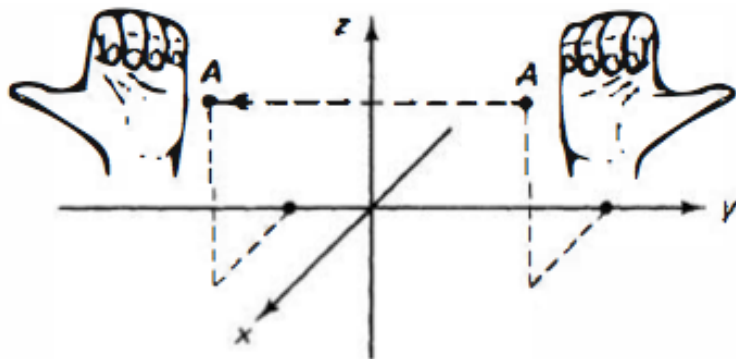

Fig. 4.10 Decay of π^- at rest.

Pion has spin 0. In rest frame, muon and anti-neutrino are back-to-back and spins must be oppositely aligned. Measure muon helicity here as always right-handed, implies anti-neutrino is always right-handed

Thinking about parity

Image from Griffiths



(a) Reflection (in the x - z plane)
 $(x, y, z) \rightarrow (x, -y, z)$

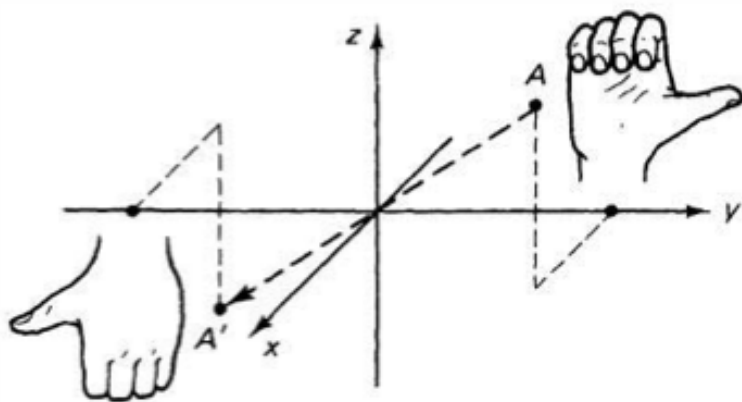

(b) Inversion $(x, y, z) \rightarrow (-x, -y, -z)$

Parity
operator P
applies
inversion

$$P(\vec{a}) = -\vec{a}, P(\vec{b}) = -\vec{b}$$

$$\vec{c} = \vec{a} \times \vec{b} \rightarrow P(\vec{c}) = -\vec{a} \times -\vec{b} = \vec{c}$$

a,b are vectors (P changes sign), c is a pseudovector, also called an axial vector, and does not change sign under P

$$P(\vec{a}) = -\vec{a}, P(\vec{b}) = -\vec{b}$$

$$\vec{c} = \vec{a} \times \vec{b} \rightarrow P(\vec{c}) = -\vec{a} \times -\vec{b} = \vec{c}$$

d is scalar (P doesn't change sign), e is a pseudoscalar (changes sign under P)

$$P(\vec{a}) = -\vec{a}, P(\vec{b}) = -\vec{b}, P(\vec{c}) = P(\vec{a} \times \vec{b}) = \vec{c}$$

$$d = \vec{a} \cdot \vec{b}, e = \vec{c} \cdot \vec{d}$$

$$P(d) = P(\vec{a} \cdot \vec{b}) = -\vec{a} \cdot -\vec{b} = d$$

$$P(e) = P(\vec{c} \cdot \vec{d}) = P(\vec{a} \times \vec{b} \cdot \vec{d}) = -\vec{a} \times -\vec{b} \cdot -\vec{d} = -e$$

P^2 is the identity operator, so P has eigenvalues ± 1 . By convention, quarks have parity = $+1$, anti-quarks have parity = -1 . (Each factor of orbital angular momentum gives an additional parity factor of -1). Photon parity = -1

Parity is a multiplicative quantum number.

What is the parity of baryons? Anti-baryons? Mesons? Vector mesons?

Theta and tau (two strange mesons) seem to have same mass, but can't be the same particle since they have different parity. This is not allowed unless weak decays violate parity! These are one and the same particle, now known as charged kaon (K^+)

$$\begin{aligned}\theta^+ &\rightarrow \pi^+ + \pi^0 & [P = (-1)^2 = +1] \\ \tau^+ &\rightarrow \pi^+ + \pi^0 + \pi^0 & [P = (-1)^3 = -1] \\ \tau^+ &\rightarrow \pi^+ + \pi^+ + \pi^- & [P = (-1)^3 = -1]\end{aligned}$$

Charge conjugation

Charge operator changes the sign of all internal quantum numbers (electron number, baryon number, electric charge, etc). NOT a symmetry of weak force

$C^2 = \text{Identity}$, but only particles that are their own anti-particles are eigenstates of C . For spin-1/2 particle and anti-particle, $C = (-1)^{L+S}$

Photon $C = -1$
(intuitive?)
Explains why neutral pions do not decay to three photons

$$\pi^0 \rightarrow \gamma\gamma$$

$$\text{so } C(\pi^0) = +1$$

Can we ask for the charge of
baryons? Anti-baryons?
Mesons? Vector mesons?
Have to be careful here, since
only objects that are their own
anti-particles are eigenstates
of charge!

$$C|\nu_{e,L}\rangle = |\bar{\nu}_{e,L}\rangle$$

Charge conjugation not a symmetry of weak interaction: left-handed anti-neutrinos do not exist

$$P|\nu_{e,L}\rangle = |\nu_{e,R}\rangle$$

Parity not a symmetry of weak interaction: right-handed neutrinos also do not exist

$$CP|\nu_{e,L}\rangle = |\bar{\nu}_{e,R}\rangle$$

What about the combination? CP symmetry

$$\pi^+ \rightarrow \mu^+ + \nu_\mu$$

What do we get if we apply
CP operators to both sides of
this decay?

Neutral kaons

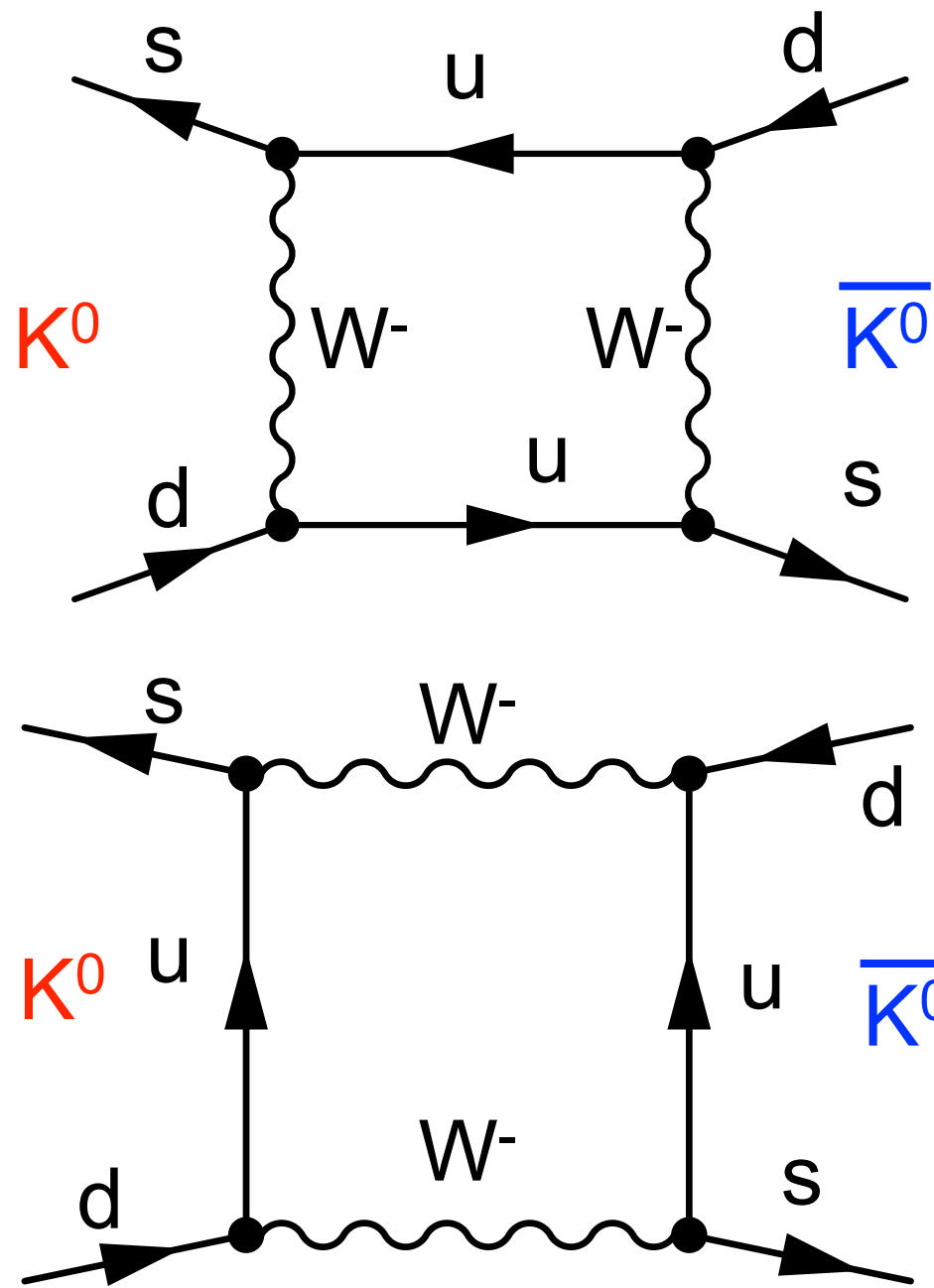

We call these “**box**” diagrams (hopefully for obvious if uncreative reasons). They are a way for neutral kaons to turn into their own antiparticles

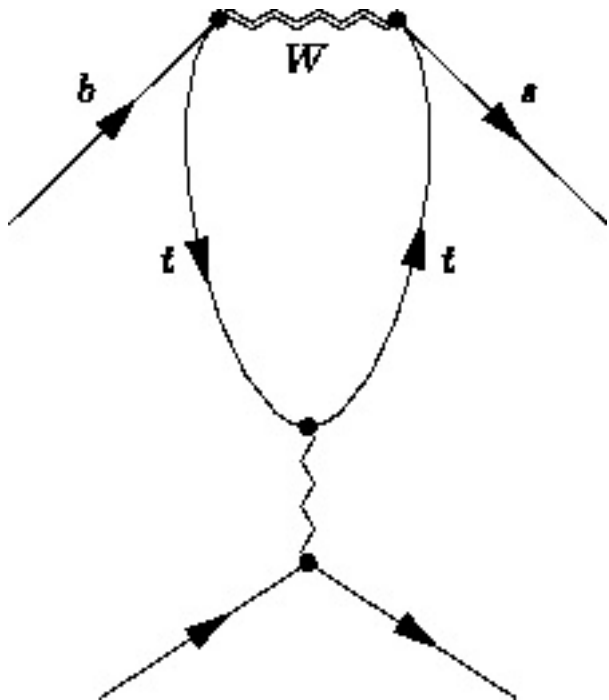

What would you call this sort of diagram? It's a bit odd, but you have two quarks coming in and two quarks coming out (plays an important role in flavor physics). Any guesses?

Fun aside on diagrams

<http://asymptotia.com/2007/05/14/penguin-opportunity/>

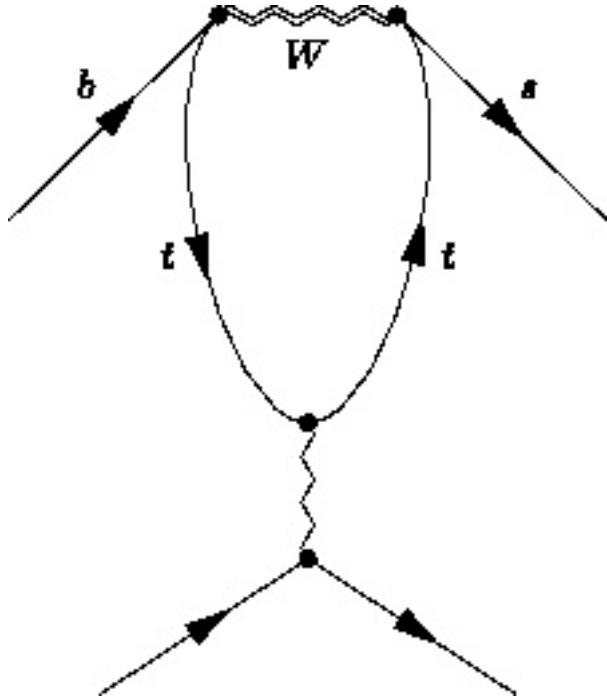

What would you call this sort of diagram? It's a bit odd, but you have two quarks coming in and two quarks coming out (plays an important role in flavor physics). Any guesses?

Fun aside on diagrams

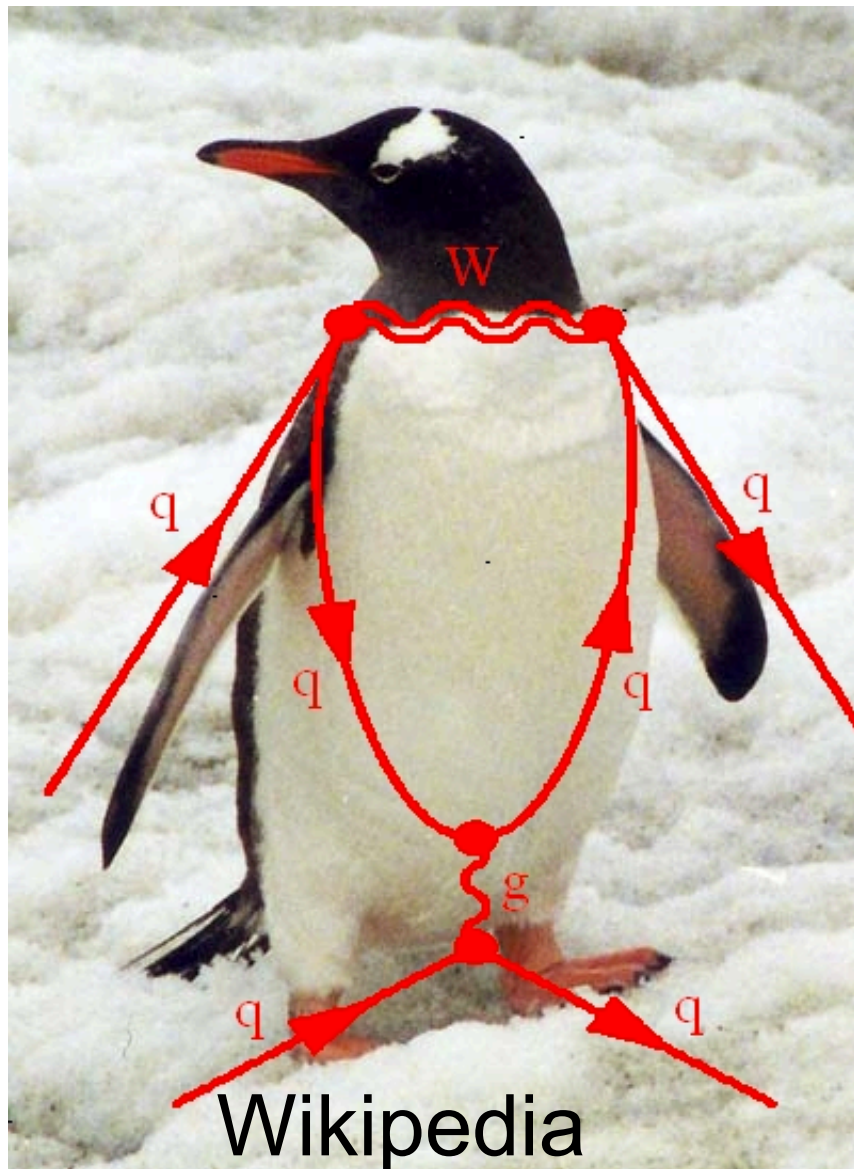

A penguin diagram! Of course. I won't even ask you to guess how the name appeared, but will just quote the explanation :)

Penguin diagrams

[http://arxiv.org/
pdf/hep-ph/
9510397v1.pdf](http://arxiv.org/pdf/hep-ph/9510397v1.pdf)

Could not have
made this up if I
tried. Disclaimer: I
do not suggest
that you can be a
better physicist or
get a better grade
this way

By the way, about penguins. From time to time students ask about how this word could possibly penetrate high energy physics. This is a funny story, indeed. The first paper where the graphs that are now called penguins were considered in the weak decays appeared in JETP Letters in 1975, and there they did not look like penguins at all. Later on they were made look like penguins and called penguins by John Ellis. Here is his story as he recollects it himself. “Mary K. [Gaillard], Dimitri [Nanopoulos] and I first got interested in what are now called penguin diagrams while we were studying CP violation in the Standard Model in 1976... The penguin name came in 1977, as follows. In the spring of 1977, Mike Chanowitz, Mary K and I wrote a paper on GUTs predicting the b quark mass before it was found. When it was found a few weeks later, Mary K, Dimitri, Serge Rudaz and I immediately started working on its phenomenology. That summer, there was a student at CERN, Melissa Franklin who is now an experimentalist at Harvard. One evening, she, I and Serge went to a pub, and she and I started a game of darts. We made a bet that if I lost I had to put the word penguin into my next paper. She actually left the darts game before the end, and was replaced by Serge, who beat me. Nevertheless, I felt obligated to carry out the conditions of the bet. For some time, it was not clear to me how to get the word into this b quark paper that we were writing at the time. Then, one evening, after working at CERN, I stopped on my way back to my apartment to visit some friends living in Meyrin where I smoked some illegal substance. Later, when I got back to my apartment and continued working on our paper, I had a sudden flash that the famous diagrams look like penguins. So we put the name into our paper, and the rest, as they say, is history.”

$$G = C e^{i\pi I_2} (\pi^+) = \pi^-$$

State with n pions has G parity $(-1)^n$
Useful for knowing how many pions an
object can decay to!

From the PDG

LIGHT UNFLAVORED ($S = C = B = 0$)		STRANGE ($S = \pm 1, C = B = 0$)		CHARMED, STRANGE ($C = S = \pm 1$)		$c\bar{c}$ $f^c(J^{PC})$			
$f^G(J^{PC})$	$f^G(J^{PC})$	$f^G(J^{PC})$	$f^G(J^{PC})$	$f^G(J^{PC})$	$f^G(J^{PC})$	$f^c(J^{PC})$	$f^c(J^{PC})$		
• π^\pm	$1^-(0^-)$	• $\phi(1680)$	$0^-(1^{--})$	• K^\pm	$1/2(0^-)$	• D_s^\pm	$0(0^-)$	• $\eta_c(1S)$	$0^+(0^-)$
• π^0	$1^-(0^-)$	• $\rho_3(1690)$	$1^+(3^{--})$	• K^0	$1/2(0^-)$	• $D_s^{*\pm}$	$0(?^?)$	• $J/\psi(1S)$	$0^-(1^{--})$
• η	$0^+(0^-)$	• $\rho(1700)$	$1^+(1^{--})$	• K_S^0	$1/2(0^-)$	• $D_{s0}^*(2317)^\pm$	$0(0^+)$	• $\chi_{c0}(1P)$	$0^+(0^+)$
• $f_0(500)$	$0^+(0^+)$	• $a_2(1700)$	$1^-(2^{++})$	• K_L^0	$1/2(0^-)$	• $D_{s1}(2460)^\pm$	$0(1^+)$	• $\chi_{c1}(1P)$	$0^+(1^+)$
• $\rho(770)$	$1^+(1^{--})$	• $f_0(1710)$	$0^+(0^+)$	• $K_1^*(800)$	$1/2(0^+)$	• $D_{s1}(2536)^\pm$	$0(1^+)$	• $h_c(1P)$	$?^?(1^+)$
• $\omega(782)$	$0^-(1^{--})$	• $\eta(1760)$	$0^+(0^-)$	• $K^*(892)$	$1/2(1^-)$	• $D_{s2}(2573)$	$0(?^?)$	• $\chi_{c2}(1P)$	$0^+(2^+)$
• $\eta'(958)$	$0^+(0^-)$	• $\pi(1800)$	$1^-(0^-)$	• $K_1(1270)$	$1/2(1^+)$	• $D_{s1}^*(2700)^\pm$	$0(1^-)$	• $\eta_c(2S)$	$0^+(0^-)$
• $f_0(980)$	$0^+(0^+)$	• $f_2(1810)$	$0^+(2^+)$	• $K_1(1400)$	$1/2(1^+)$	• $D_{sJ}^*(2860)^\pm$	$0(?^?)$	• $\psi(2S)$	$0^-(1^{--})$
• $a_0(980)$	$1^-(0^+)$	• $X(1835)$	$?^?(?^-)$	• $K^*(1410)$	$1/2(1^-)$	• $D_{sJ}(3040)^\pm$	$0(?^?)$	• $\psi(3770)$	$0^-(1^{--})$
• $\phi(1020)$	$0^-(1^{--})$	• $X(1840)$	$?^?(?^{??})$	• $K_0^*(1430)$	$1/2(0^+)$			• $X(3823)$	$?^?(?^?)$
• $h_1(1170)$	$0^-(1^+)$	• $\phi_3(1850)$	$0^-(3^{--})$	• $K_2^*(1430)$	$1/2(2^+)$	BOTTOM ($B = \pm 1$)		• $X(3872)$	$0^+(1^+)$
• $b_1(1235)$	$1^+(1^+)$	• $\eta_2(1870)$	$0^+(2^-)$	• $K(1460)$	$1/2(0^-)$	• B^\pm	$1/2(0^-)$	• $X(3900)^\pm$	$?(1^+)$
• $a_1(1260)$	$1^-(1^+)$	• $\pi_2(1880)$	$1^-(2^-)$	• $K_2(1580)$	$1/2(2^-)$	• B^0	$1/2(0^-)$	• $X(3900)^0$	$?(?^?)$
• $f_2(1270)$	$0^+(2^+)$	• $\rho(1900)$	$1^+(1^-)$	• $K(1630)$	$1/2(?^?)$	• B^\pm/B^0 ADMIXTURE		• $\chi_{c0}(3915)$	$0^+(0^+)$
• $f_1(1285)$	$0^+(1^+)$	• $f_2(1910)$	$0^+(2^+)$	• $K_1(1650)$	$1/2(1^+)$	• $B^\pm/B^0/B_s^0/b$ -baryon ADMIXTURE		• $\chi_{c2}(2P)$	$0^+(2^+)$
• $\eta(1295)$	$0^+(0^-)$	• $f_2(1950)$	$0^+(2^+)$	• $K^*(1680)$	$1/2(1^-)$	• V_{cb} and V_{ub} CKM Ma- trix Elements		• $X(3940)$	$?^?(?^{??})$
• $\pi(1300)$	$1^-(0^-)$	• $\rho_3(1990)$	$1^+(3^{--})$	• $K_2(1770)$	$1/2(2^-)$	• B^*	$1/2(1^-)$	• $X(4020)^\pm$	$?(?^?)$
• $a_2(1320)$	$1^-(2^+)$	• $f_2(2010)$	$0^+(2^+)$	• $K_3^*(1780)$	$1/2(3^-)$	• $B_1(5721)^+$	$1/2(1^+)$	• $\psi(4040)$	$0^-(1^{--})$
• $f_0(1370)$	$0^+(0^+)$	• $f_0(2020)$	$0^+(0^+)$	• $K_2(1820)$	$1/2(2^-)$	• $B_1(5721)^0$	$1/2(1^+)$	• $X(4050)^\pm$	$?(?^?)$
• $h_1(1380)$	$?^-(1^+)$	• $a_4(2040)$	$1^-(4^+)$	• $K(1830)$	$1/2(0^-)$			• $X(4140)$	$0^+(?^+)$
• $\pi_1(1400)$	$1^-(1^-)$	• $f_4(2050)$	$0^+(4^+)$	• $K_0^*(1950)$	$1/2(0^+)$			• $\psi(4160)$	$0^-(1^{--})$

Back to more ... geometric animals

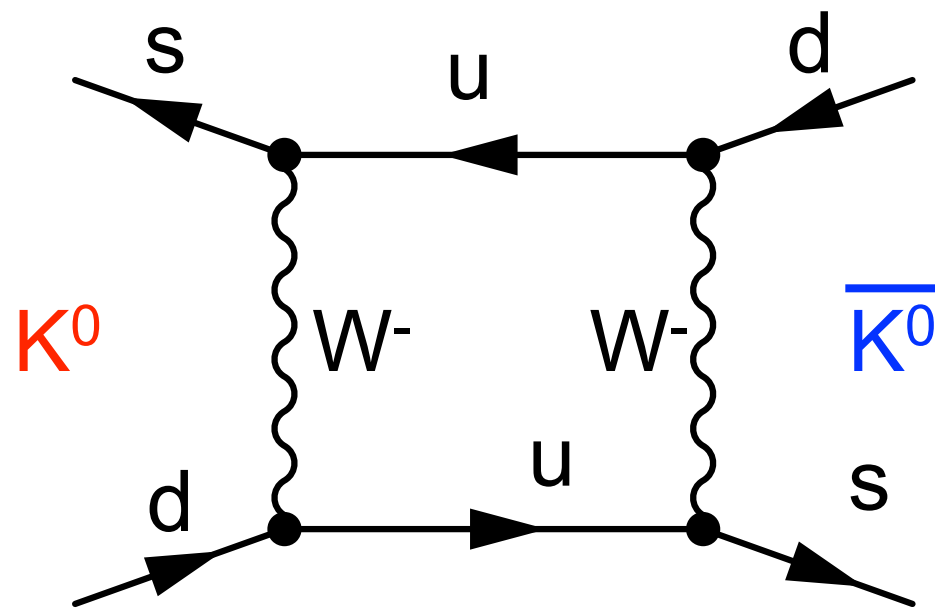

Is the -1 (and not +1) eigenvalue for parity obvious?

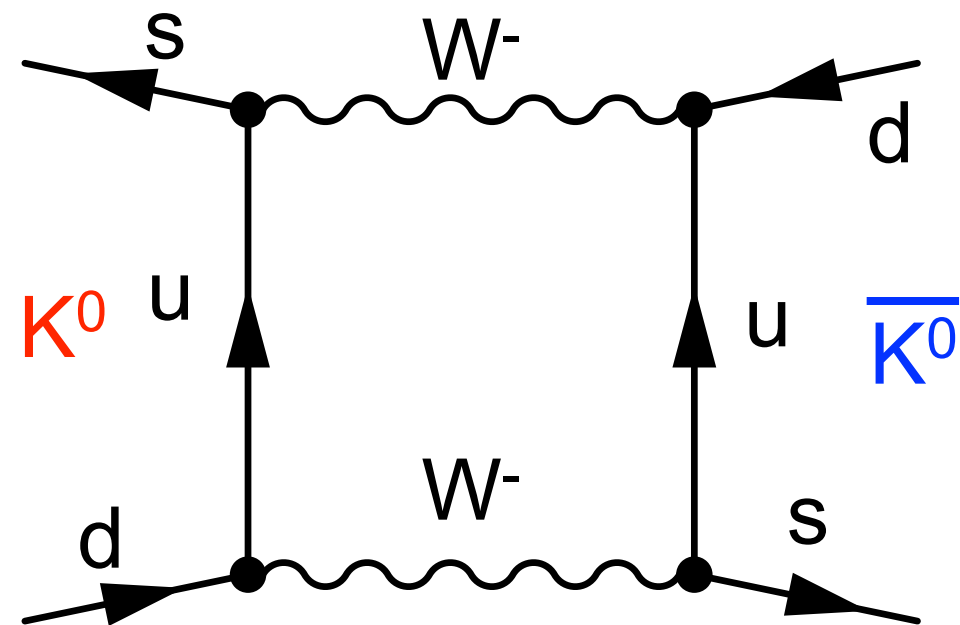

$$C|K^0\rangle = |\bar{K}^0\rangle$$

$$C|\bar{K}^0\rangle = |K^0\rangle$$

$$P|K^0\rangle = -|\bar{K}^0\rangle$$

$$P|\bar{K}^0\rangle = -|K^0\rangle$$

CP for neutral kaons

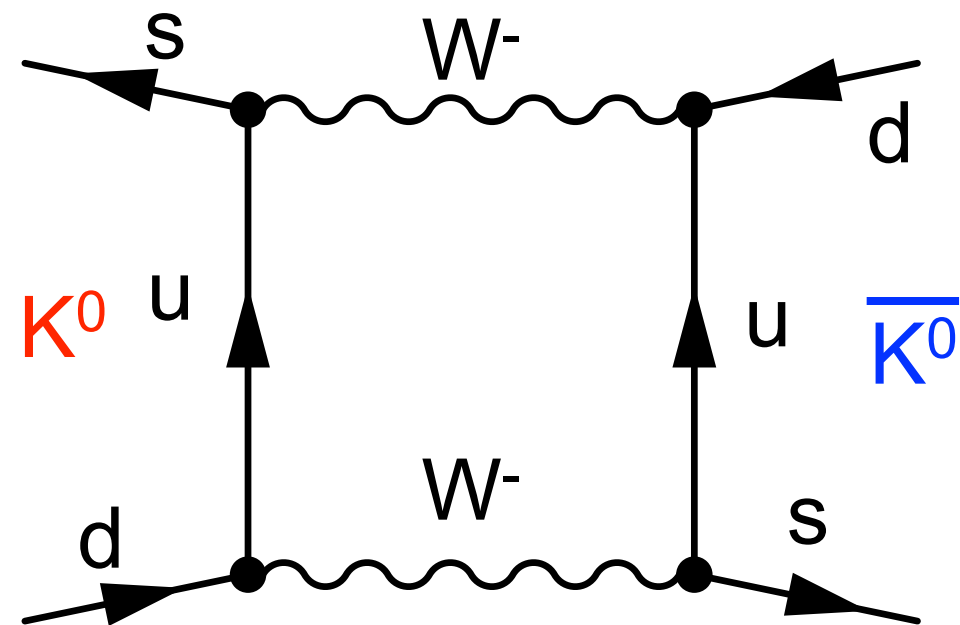
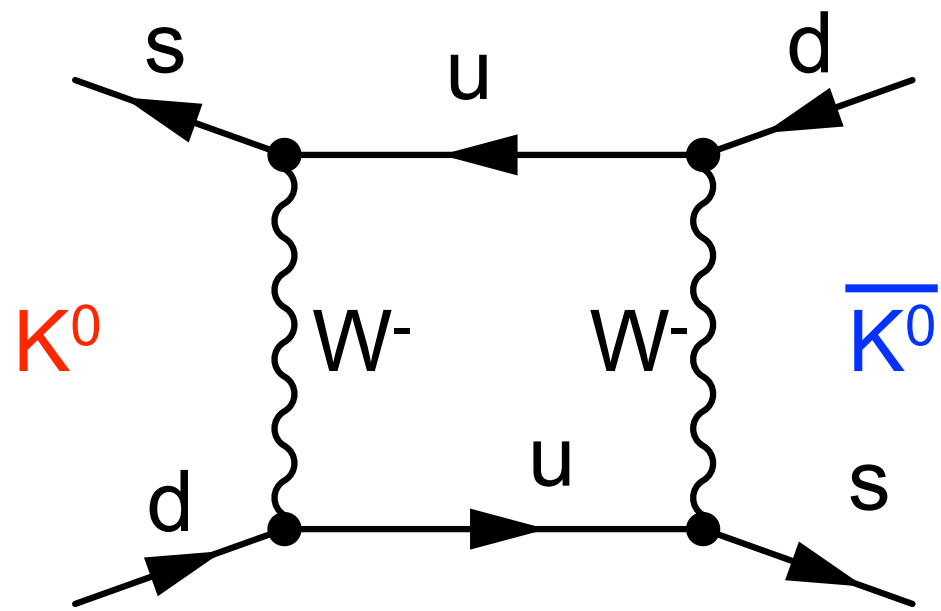

$$C|K^0\rangle = |\bar{K}^0\rangle$$

$$C|\bar{K}^0\rangle = |K^0\rangle$$

$$P|K^0\rangle = -|\bar{K}^0\rangle$$

$$P|\bar{K}^0\rangle = -|K^0\rangle$$

So...

$$CP|K^0\rangle = -|\bar{K}^0\rangle$$

$$CP|\bar{K}^0\rangle = -|K^0\rangle$$

$$CP|K_1\rangle = |K_1\rangle, CP|K_2\rangle = -|K_2\rangle$$

$$|K_1\rangle = \frac{1}{\sqrt{2}} \left(|K^0\rangle - |\bar{K}^0\rangle \right)$$

$$|K_2\rangle = \frac{1}{\sqrt{2}} \left(|K^0\rangle + |\bar{K}^0\rangle \right)$$

K_1 and K_2 are the eigenstates of CP, not the kaon and anti-kaon! If weak interactions conserve CP, then they will have different decays

CP for neutral kaons

$$CP|K^0\rangle = -|\bar{K}^0\rangle$$

$$CP|\bar{K}^0\rangle = -|K^0\rangle$$

$$CP|K_1\rangle = |K_1\rangle, CP|K_2\rangle = -|K_2\rangle$$

$$|K_1\rangle = \frac{1}{\sqrt{2}} (|K^0\rangle - |\bar{K}^0\rangle)$$

$$|K_2\rangle = \frac{1}{\sqrt{2}} (|K^0\rangle + |\bar{K}^0\rangle)$$

Neutral kaons decay most of the time to two-pion and three-pion final states

What is CP of the pions that kaons can decay to?
Let's start with two-pion decay:

$$K^0/\bar{K}^0 \rightarrow \pi^+\pi^-$$

$$K^0/\bar{K}^0 \rightarrow \pi^0\pi^0$$

$$\pi^0 = \frac{1}{\sqrt{2}} (u\bar{u} - d\bar{d})$$

$$\pi^+ = ud$$

$$\pi^- = \bar{u}\bar{d}$$

CP for neutral kaons

What is CP of the pions that kaons can decay to?
Let's start with two-pion decay:

$$\pi^+ = ud$$

$$\pi^- = \bar{u}\bar{d}$$

$$C|\pi^+ \rangle = |\pi^- \rangle$$

$$P|\pi^+ \rangle = -|\pi^- \rangle$$

$$C|\pi^- \rangle = |\pi^+ \rangle$$

$$P|\pi^- \rangle = -|\pi^+ \rangle$$

$$CP|\pi^- \pi^+ \rangle = +|\pi^- \pi^+ \rangle$$

$$K^0/\bar{K}^0 \rightarrow \pi^+ \pi^-$$

$$K^0/\bar{K}^0 \rightarrow \pi^0 \pi^0$$

$$\pi^0 = \frac{1}{\sqrt{2}}(u\bar{u} - d\bar{d})$$

$$C|\pi^0 \rangle = |\pi^0 \rangle$$

$$P|\pi^0 \rangle = -|\pi^0 \rangle$$

$$CP|\pi^0 \pi^0 \rangle = +|\pi^0 \pi^0 \rangle$$

So two pion decay is
CP even

What about three-pion decay?

$$K^0/\bar{K}^0 \rightarrow \pi^+ \pi^- \pi^0$$

$$K^0/\bar{K}^0 \rightarrow \pi^0 \pi^0 \pi^0$$

So three pion decay is CP odd

$$C|\pi^+ \pi^- \pi^0 \rangle = +1|\pi^+ \pi^- \pi^0 \rangle$$

$$C|\pi^0 \pi^0 \pi^0 \rangle = +1|\pi^0 \pi^0 \pi^0 \rangle$$

$$P|\pi^+ \pi^- \pi^0 \rangle = -1|\pi^+ \pi^- \pi^0 \rangle$$

$$P|\pi^0 \pi^0 \pi^0 \rangle = -1|\pi^0 \pi^0 \pi^0 \rangle$$

$$CP|\pi^+ \pi^- \pi^0 \rangle = -1|\pi^+ \pi^- \pi^0 \rangle$$

$$CP|\pi^0 \pi^0 \pi^0 \rangle = -1|\pi^0 \pi^0 \pi^0 \rangle$$

What does this mean?

$$CP|K^0\rangle = -|\bar{K}^0\rangle$$

$$CP|\bar{K}^0\rangle = -|K^0\rangle$$

Over long distance,
only K longs remain!

$$CP|K_1\rangle = |K_1\rangle, CP|K_2\rangle = -|K_2\rangle$$

$$|K_1\rangle = \frac{1}{\sqrt{2}} \left(|K^0\rangle - |\bar{K}^0\rangle \right) \quad K_1 = K_S = \text{"K short"},$$

lifetime $\sim 9 \times 10^{-11}$ s

$$|K_2\rangle = \frac{1}{\sqrt{2}} \left(|K^0\rangle + |\bar{K}^0\rangle \right) \quad K_2 = K_L = \text{"K long"}$$

lifetime $\sim 5 \times 10^{-8}$ s

Assuming no CP violation in weak force,
one eigenstate of kaons decays to two
pions, the other to three pions. Three pion
decay is closer to threshold, so it should be
slower: K_2 should have longer lifetime

Need to consider different types of eigenstates. We observe quark/mass eigenstates $d/s/b$, but weak force couples to modified flavor versions $d'/s'/b'$

Kaons produced in eigenstates of strangeness, but oscillate back and forth, and decay as eigenstates of CP (mostly!)

Weak interactions couple to flavor eigenstates for neutrinos, but mass eigenstates are different!

It turns out that this isn't the full story

James Cronin and Val Fitch showed that weak interactions DO violate CP symmetry. Some K_L decay to two pions! Just not very often (~ 2 out of every thousand decays to pions). **Matter and anti-matter are not the same!** Led to prediction of third generation of quarks

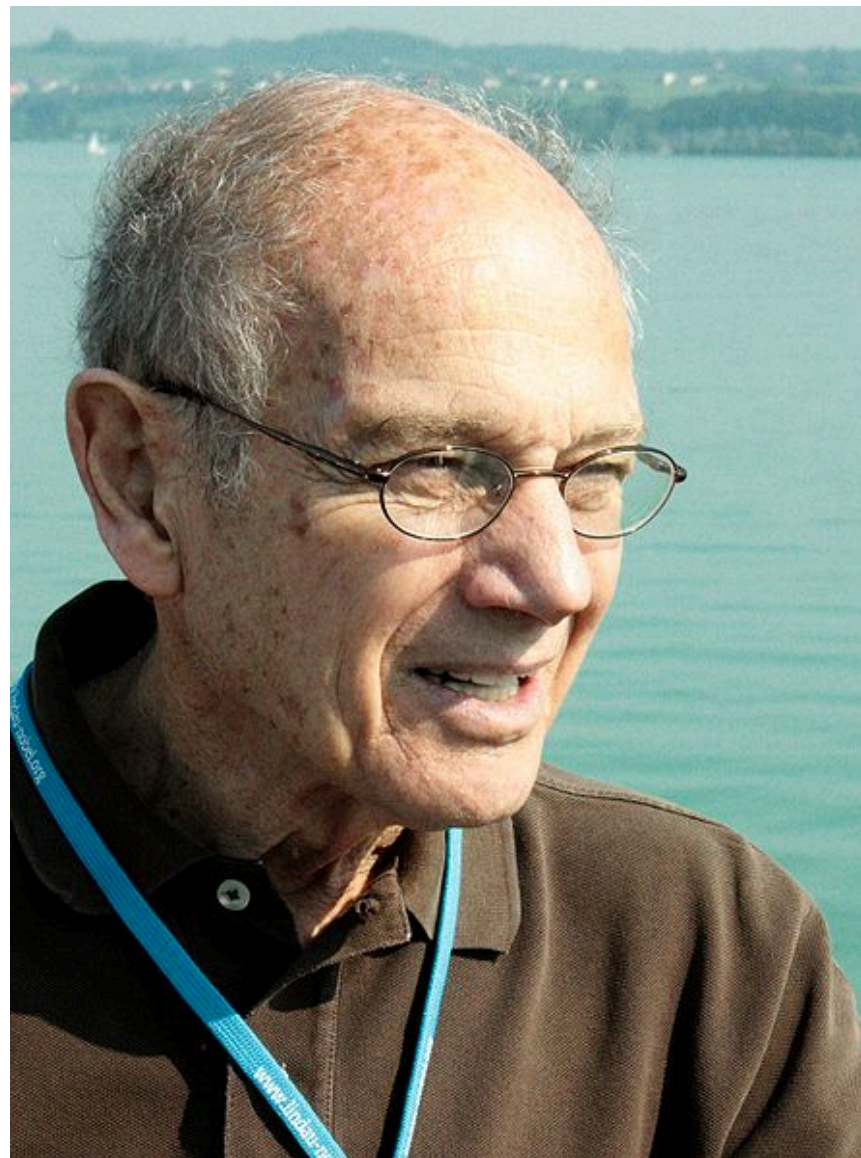

James Cronin

It turns out that even this isn't the full story

K_L prefers to decay to

$$\pi^+ + e^- + \bar{\nu}_e$$

instead of

$$\pi^- + e^+ + \nu_e$$

by a few parts in a thousand! Matter and anti-matter are not really the same thing (well, we knew that already)

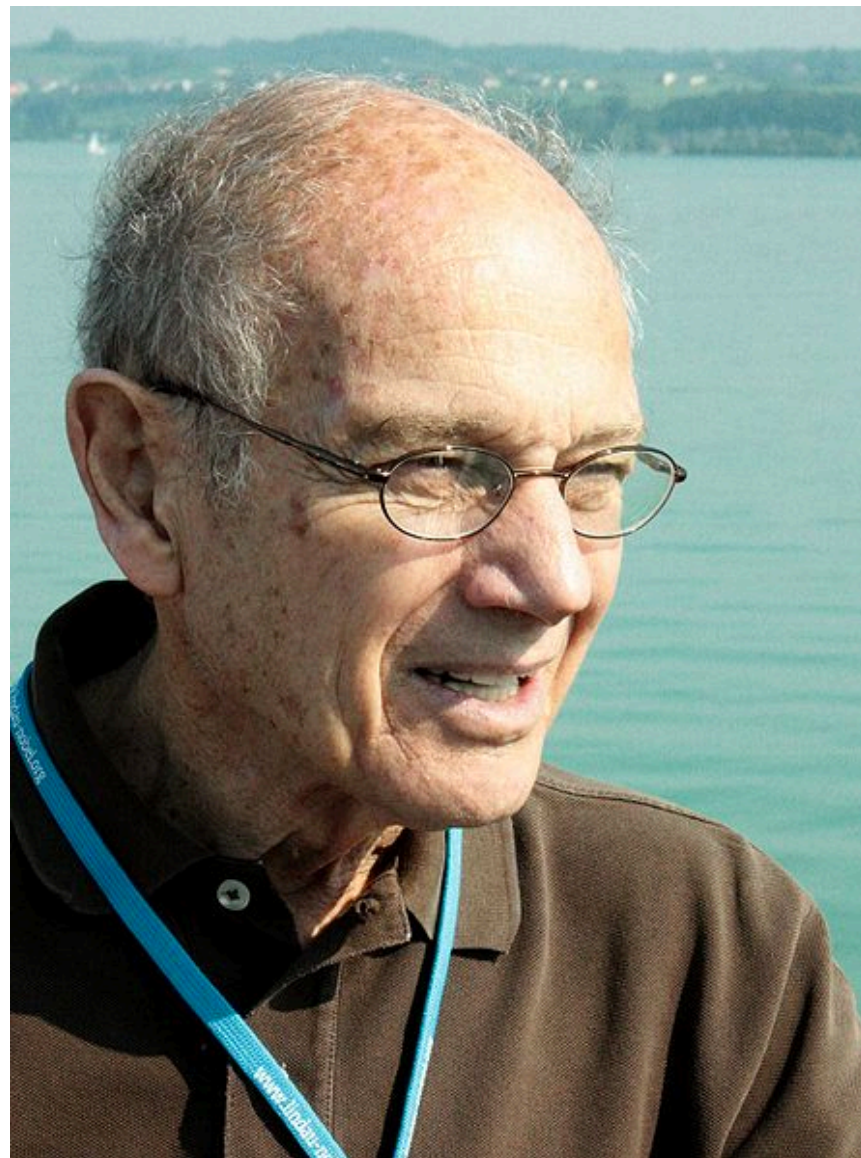

James Cronin

Belle II Detector

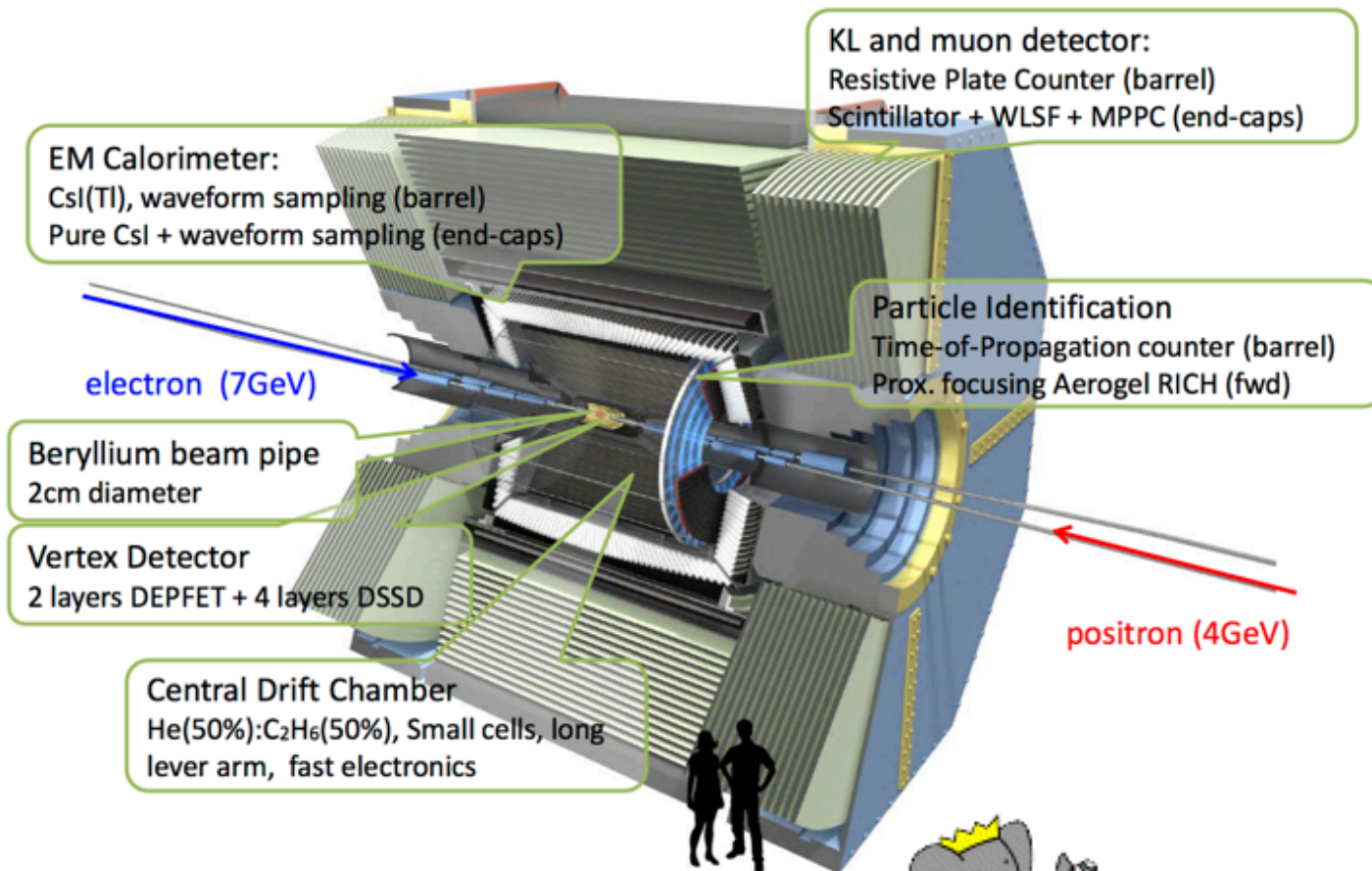

BABAR