

Experience with MRS (R&D for DHCAL LC)

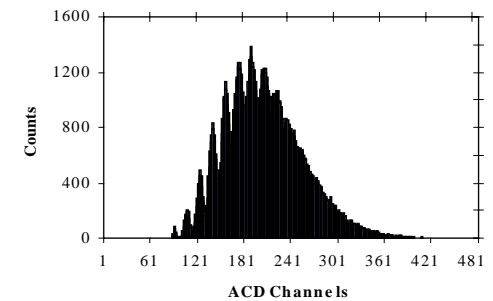

Presented by Victor Rykalin

For NICADD (Northern Illinois Center for Accelerator and Detector Development)



MRS basics

The MRS (Metal Resistive Semiconductor) photodiode is a multi-pixel solid-state device with every pixel operating in the Limited Geiger multiplication mode. Avalanche quenching is achieved by a resistive layer on the sensor surface. The device has a large number of pixels, about 1500 per 1x1 mm sensor . The quantum efficiency (QE) of the device reaches 25% at 500nm, comparable to the QE of a conventional green-extended Photo Multiplier Tube (PMT).

MRS 8 channel PC board

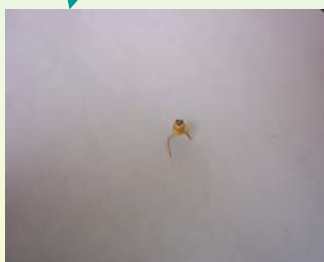
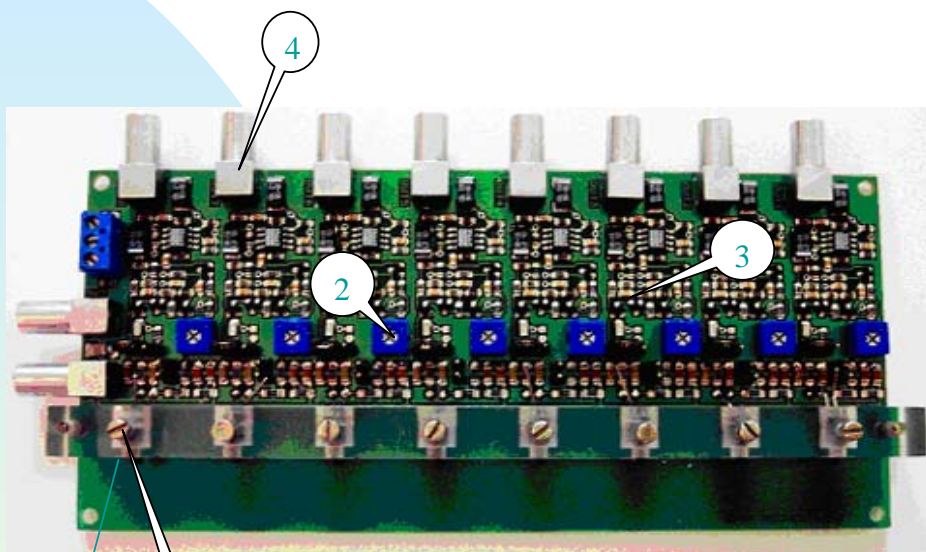
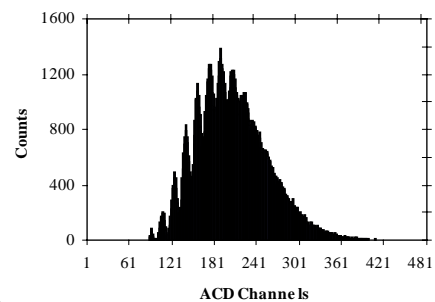
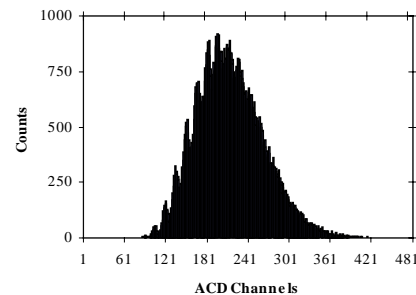

Fig. 1. 8 - channel MRS board. 1 – MRS sensor, 2 – bias voltage tuner, 3 – preamplifier, 4 – signal output



Channel 1.



Channel 3.

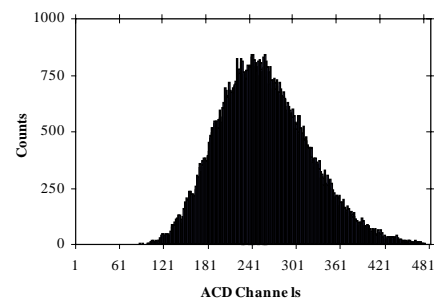

Channel 5.

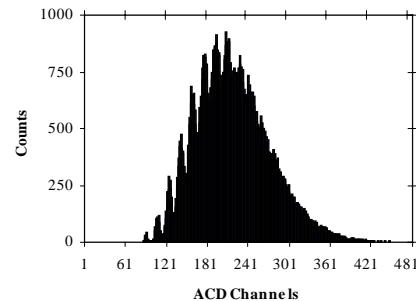

Channel 7.

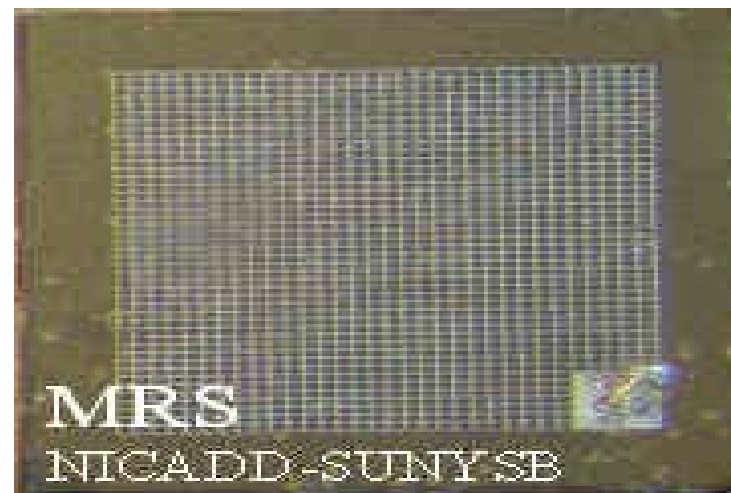

Working point of MRS

Fig. 2 shows the output signal frequency versus the bias voltage for three different threshold values. They were chosen so that the efficiency of the signal detection was close to 100% for the majority of the bias voltages. The plateau (from ~50.0V to ~51.0V) is a region of full signal detection with the least amount of internal noise, where amplification and QE increase towards the right side of the graph.

These measurements were done for three different bias voltages (Fig. 3). The bias voltages chosen are at the beginning of the plateau (49.6V), at its end (50.6V) and at some point outside the plateau but near its end (52.0V).

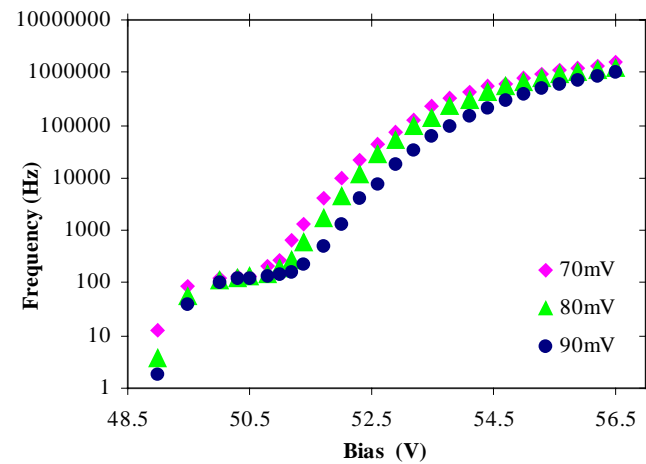

Fig. 2 Signal dependence on bias voltage at different thresholds (~150Hz signal from LED is supplied to MRS).

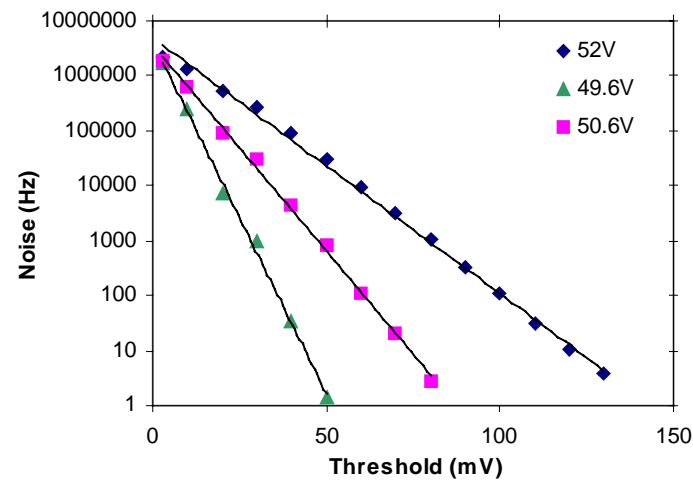

Fig.3 Noise dependence on the threshold for different bias voltages. At 49.6V we have 1PE ~ 40mV, at 50.6V - 1PE ~ 50mV, at 52V - 1PE ~ 60mV.

Working point of MRS

The amplitude of the output signal was measured and plotted versus the bias voltage (Fig. 4). After some value of the bias voltage, further increase in voltage doesn't yield an increase in amplification. This point can be also used as a definition of working point. However, at such high bias voltage the detector is close to the breakdown voltage; it generates high-frequency noise that might not be suitable for some application.

For the third test, the average amplitude of the dark noise of the sensor was measured separately (with the LED turned off). Then the Signal-to-Noise (S/N) ratio was calculated at each corresponding value of the bias voltage, using the data acquired in this test and from Fig. 4. The results are plotted in Fig. 5; a distinct peak corresponds to the optimal balance between the levels of noise and the amplification of the sensor.

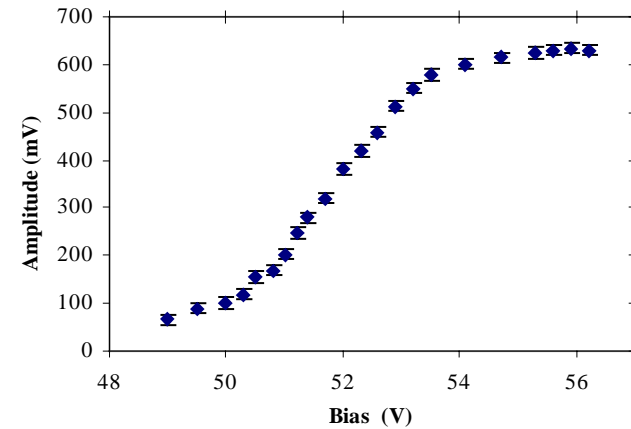

Fig. 4. Signal amplitude versus the bias voltage.

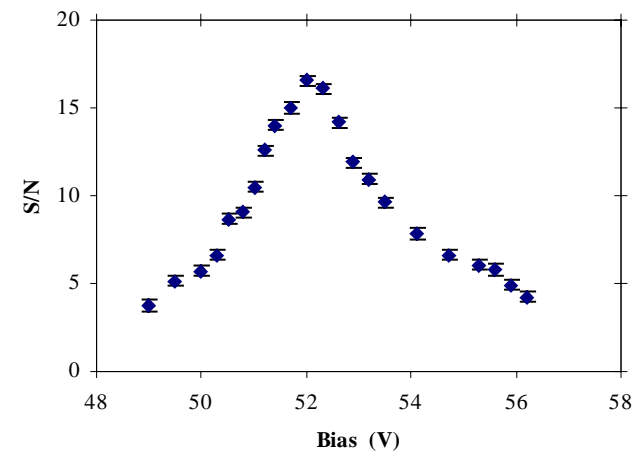

Fig. 5. Signal-to-noise value versus bias voltage for MRS.

LED measurements

The apparatus schematic in Fig. 6 was used to carry out the LED measurements. In order to simulate the scintillating cell output, a blue (max in ~ 450nm) LED was used. The LED was positioned in such way that the majority of the emitted light was across to KURARAY Y-11, 1mm, round, WLS fiber of ~1m long, ensuring that blue light doesn't reach the photodetector directly.

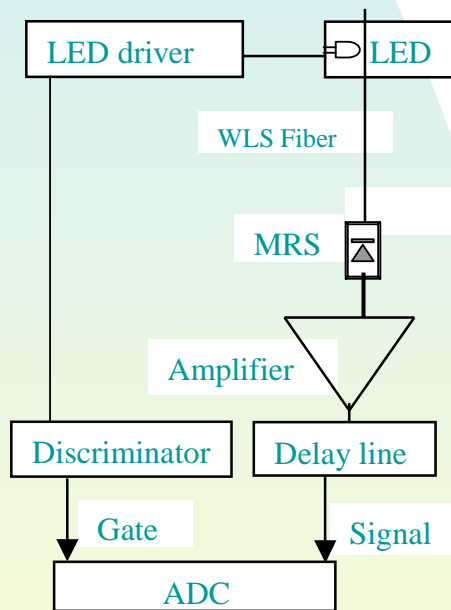

Fig. 6. Apparatus schematics used for LED measurements

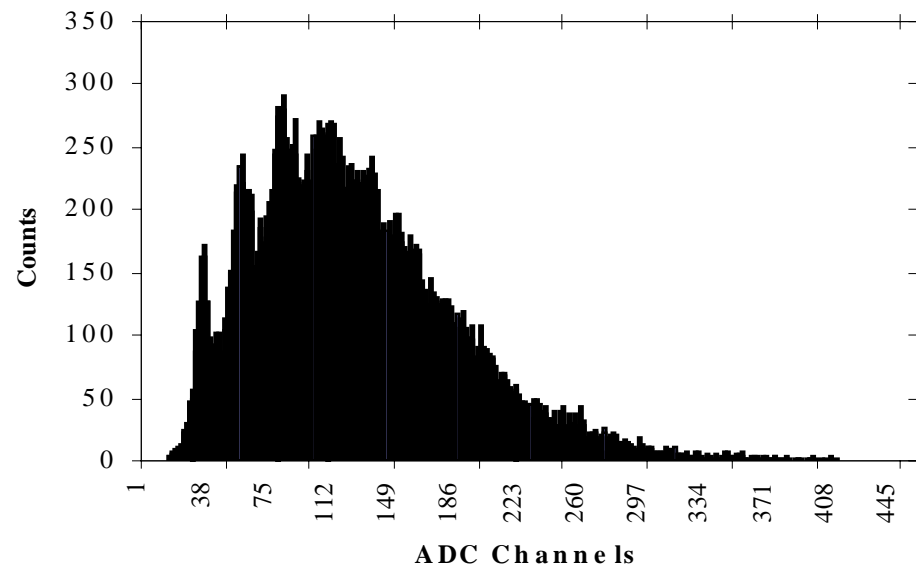

Fig. 7. MRS response to LED Signal. MRS was at 52.0V, gate of ~50ns used. Pedestal was in channel 38.

MRS response to scintillating strip signal from cosmic rays

The test was performed using scintillating strip with cosmic rays as the source of Minimum Ionizing Particles (MIPs). The strip used was made from extruded scintillator with co-extruded hole along the strip, 1m long, 5cm wide and 5mm thick. 1.5m long KURARAY Y-11, 1.0mm outer diameter, round, multicladd, WLS fiber with mirrored end, was embedded and glued, with 0.15m of fiber from the edge of the strip to the MRS. MRS was biased at 52.0V, gate of ~50ns and double-coincidence trigger of equal area were used. Fig. 8 shows the apparatus schematics used for cosmic measurements. Fig. 9 shows the cosmic ray signal with the MRS. Using calibration data from the LED measurements for 1PE, we estimate the signal level at 17PE .

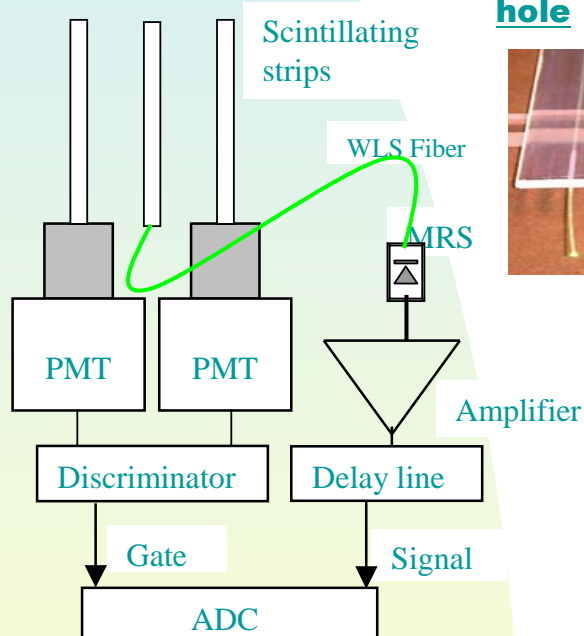

Fig. 8. Apparatus schematics used for cosmic measurements.

Extruded FNAL-NICADD scintillator, with co-extruded hole

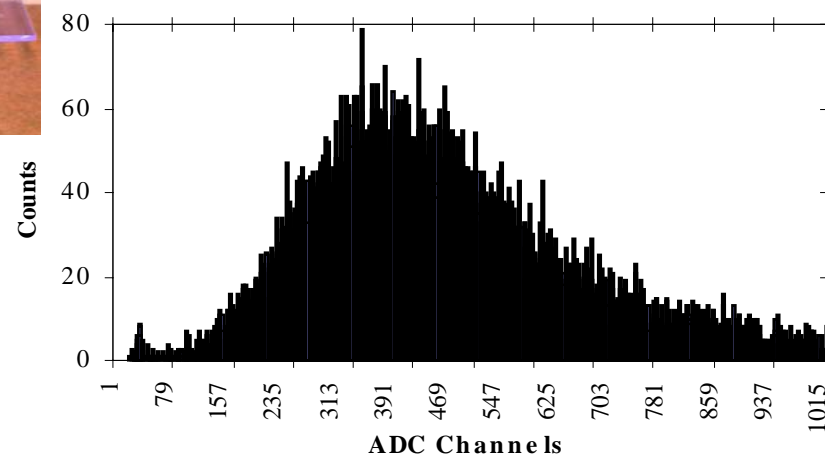
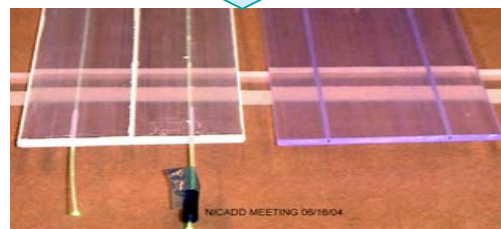

Fig. 9. MRS response to scintillating strip signal from cosmic rays. MRS was at 52.0V, gate of ~50ns used. Pedestal was in channel 38. Get 17PE.

MRS scan



The dependence of the output from MRS on the fiber alignment with the sensor was measured. Scans with fiber moving along, away and angled to the sensor were conducted

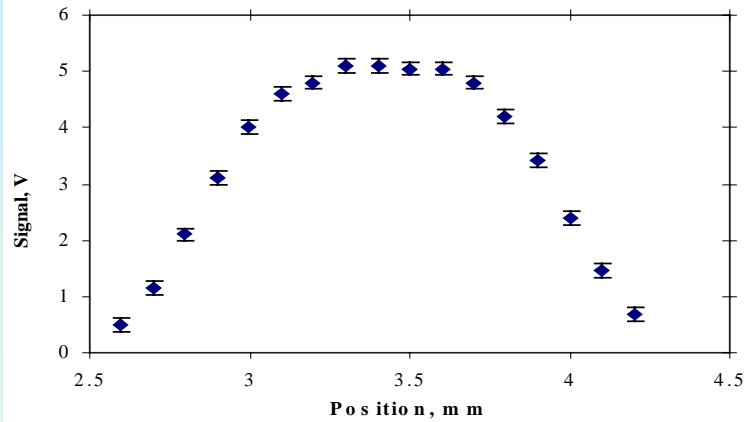

Fig. 10. Output signal amplitude versus position of the fiber along the MRS sensor.

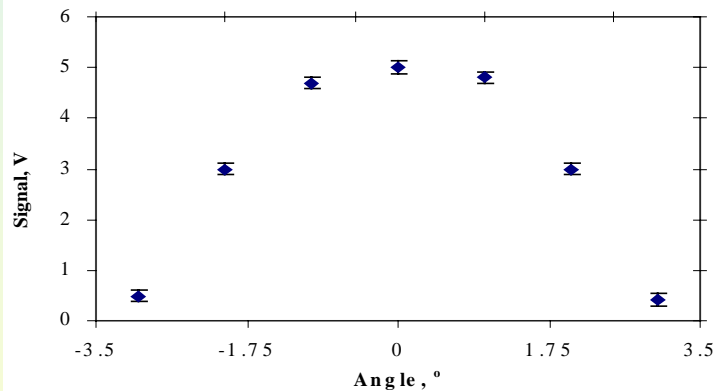

Fig. 11. Output signal amplitude versus angle of the 0.5mm fiber to the MRS sensor surface.

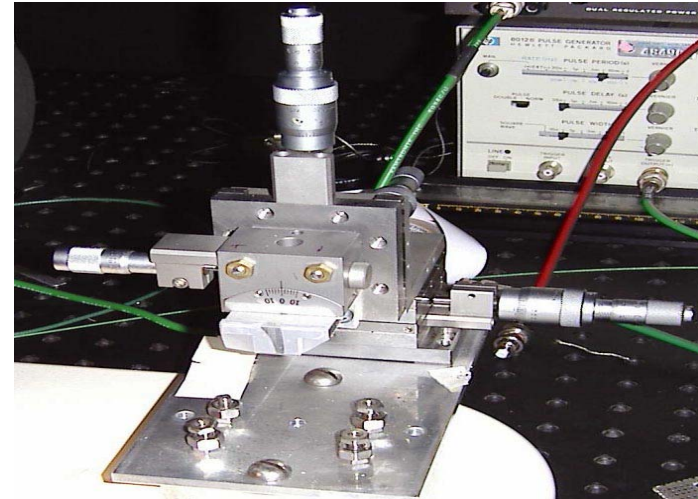

Fig. 12. 462 series XYZ-M used

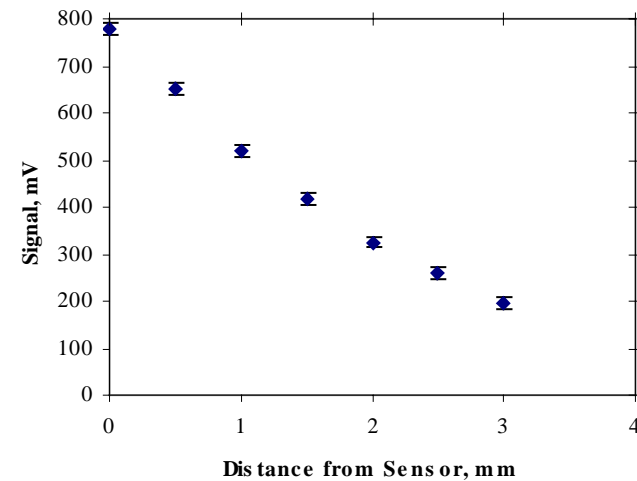

Fig. 12. Output signal amplitude versus fiber distance from the sensor.

MRS temperature measurements

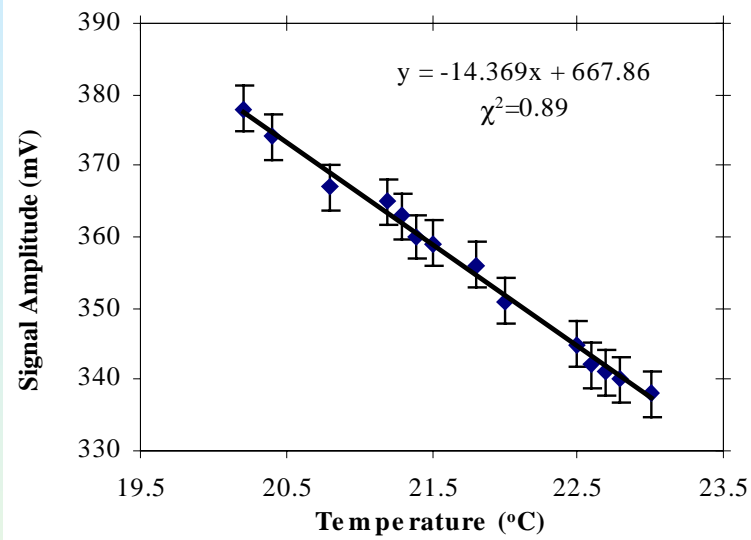

Fig. 13. Signal amplitude versus temperature.

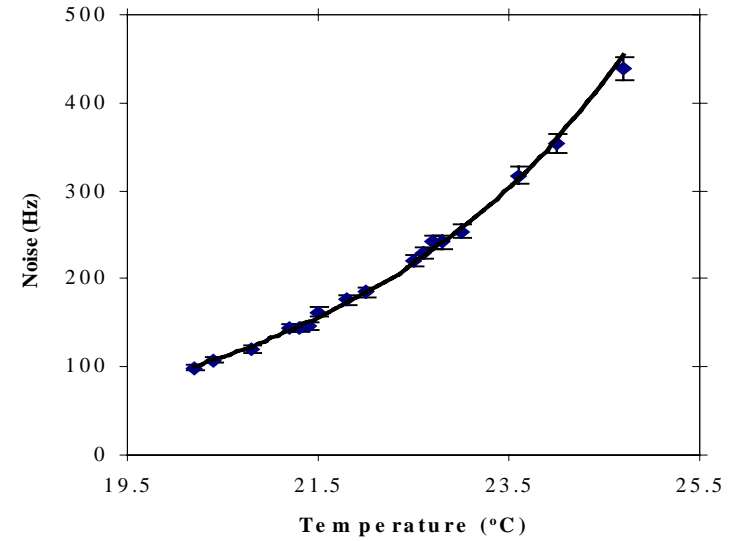

Fig. 14. Noise frequency versus temperature.

Irradiation Effects

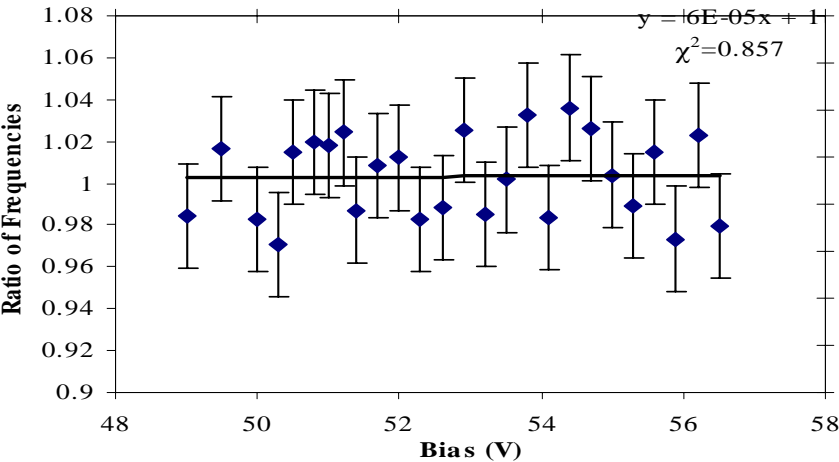

Fig. 15. Ratio of frequencies.

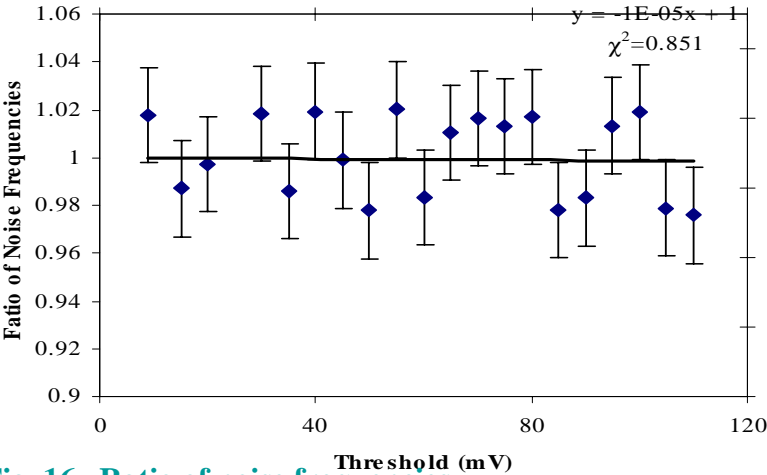
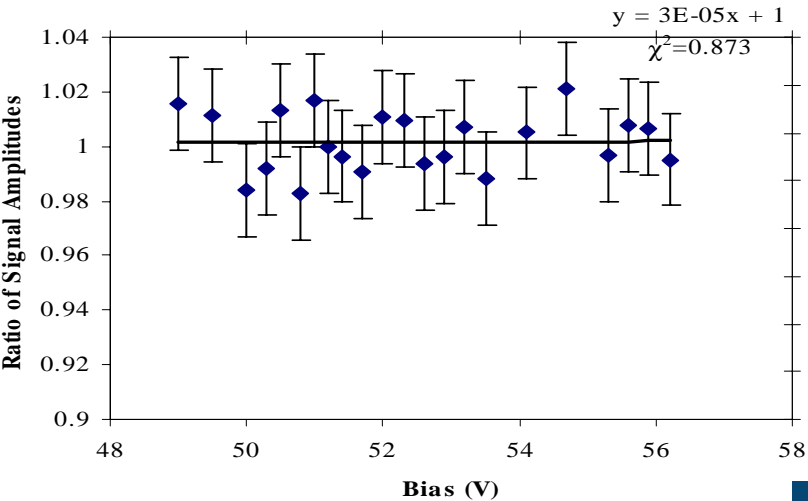

Fig. 16. Ratio of noise frequencies.



A separate study was undertaken to observe changes in the MRS sensor response after its irradiation with a dose of 1Mrad using gamma rays. The following parameters of the sensor :noise, amplification, signal detection, and bias voltage range for the sensor, were measured before and after the irradiation.

Within error bars , all the ratios are very close to 1.

Fig. 17. Ratio of signal Amplitudes.

Linearity range of MRS

From Fig11. The deviation from linearity of the level of up to 5 % starts at ~2200 photons (~550 PE in MRS response), and the deviation of the level of 10% with light intensity up to ~3000 photons (~770PE).

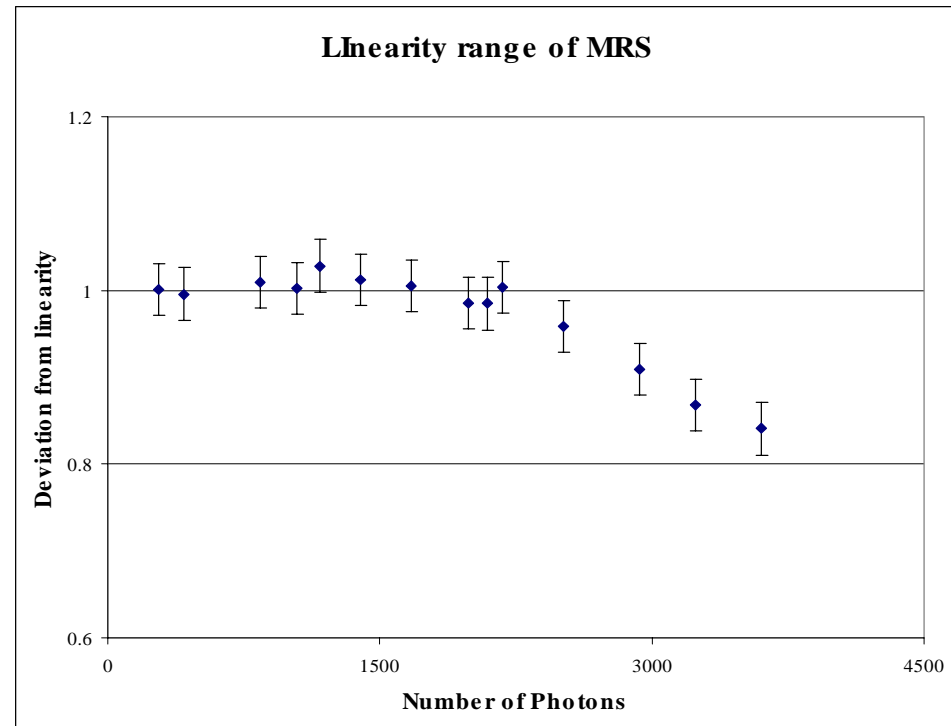
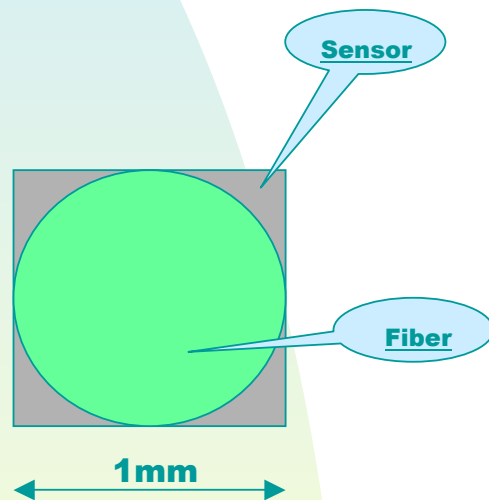

Fig. 18. Linearity range of MRS.

Summary

- 1. Measurements performed using cosmic rays with 5mm thick extruded scintillator, allow clear distinction of the MIP signal. Clear PE separation can be seen from the LED measurements.**
- 2. The device operates in the linear mode , up to 2000 of photons.**
- 3. Noise studies indicate that single-electron noise dominates and placing the threshold at the 1PE level allows reducing noise by about 2500 times (at chosen working point).**
- 4. The tilt of the fiber from the normal to the sensor surface of 1 degree results in only 4% loss of the output. On the other hand, an air gap of 0.5 mm between fiber and the sensor decreases the output by ~17 %**
- 5. Tested sensors are well suited to use with scintillator tiles.**